

428

Sales manager : Tim Ma
Tel/whatsapp/wechat : 86 18761599716
E-mail : tim.ma@email.acrel.cn
Website: www.acrel.gr



ARD3M Intelligent motor Protector

Operating Manual V1.2

ACREL Co., Ltd

Declaration

All rights Reserved. Without the written permission of the Company, the contents of any paragraph or section in this manual shall not be copied, copied or disseminated in any form. Otherwise, all consequences shall be borne by the violator.

Our company Reserves all legal rights.

Our company Reserves the right to modify the product specifications described in this manual without prior notice. Before placing an order, please consult your local agent for new specifications of this product

Catalog

1、 Overview.....	1
2、 Product Features.....	1
3、 Model specification.....	2
4、 Main parameters.....	3
5、 Dimensions and installation.....	6
6、 Protection function description.....	13
7、 Function Settings and instructions.....	27
8、 Communication Settings and instructions.....	48
9、 Typical application scheme.....	96
10、 Brief Introduction of Featured Functions.....	100
11、 Sample order.....	106

1 Overview

The ARD3M intelligent motor protector (hereinafter referred to as the protector) is suitable for low-voltage motor circuits with rated voltage up to 660V and integrates protection, measurement, control, communication, operation and maintenance. Its perfect protection function ensures the safe operation of the motor, with logic programmable function, can meet a variety of control methods. Different communication modules can be selected to meet the needs of field communication.

Product Implementation standards:

——GB 14048.4-2010 Low-voltage switchgear and controlgear -- Part 4-1: Contactors and motor starters -- Electromechanical contactors and motor starters (including motor protectors);

——JBT 10736-2007 Low voltage motor protector.

2 Product Features

- The auxiliary power type is optional. The AC220V power module supports the power range of AC85-265V/DC100-300V and the AC380V power module supports the power range of AC/DC100-415V.
- Support fundamental and full-wave power parameter measurement (U, I, P, Q, S, PF, F, EP, EQ), voltage and current imbalance degree, voltage and current positive sequence, negative sequence, zero sequence component, three-phase voltage phase angle, residual current, voltage and current 2-63 sub-harmonic measurement, sub-harmonic inclusion rate and total harmonic distortion rate.
- Protection functions include overload inverse time, overload definite time, grounding, starting a timeout, leakage, under load, locked-rotor, obstruction, short circuit, phase, overflow, imbalance (current, voltage, power, less power, overvoltage, undervoltage, phase sequence, temperature, time, external fault, tE starting number, running time, alarm, fault alarm.
- 10 channels programmable DI input, the default use of DC24V power supply, or external active wet contact can be selected (see the selection table).
- 6 channels programmable DO output, to meet the direct starting, Y- Δ starting, auto-transformer starting, and other starting modes, can be through the communication bus to achieve the master station to the motor remote control "start/stop".
- Optional anti-shaking function: support immediate restart of shaking power and restart of voltage loss.
- 2 MODBUS_RTU communication channels are standard, and PROFIBUS DPV1, Ethernet and Profinet communication modules are available for selection.
- Optional 2 channels DC4-20mA analog output interface, connected with DCS system, can realize the monitoring of field equipment.
- With fault record, start record, stop record, DI displacement record, restart record and other records of various events, you can view a number of motor operation and maintenance information, and can record the motor operation record for 1-5 hours at the same time.
- The display interface supports Chinese/English liquid crystal display
- It supports exporting waveform record and event record data on usb flash disk, and can open exporting event record file with EXCEL.

- WIFI function can be added when color LCD is optional, and relevant data of motor protector can be viewed and set by connecting the WIFI via mobile phone or computer.

3、 Model Description

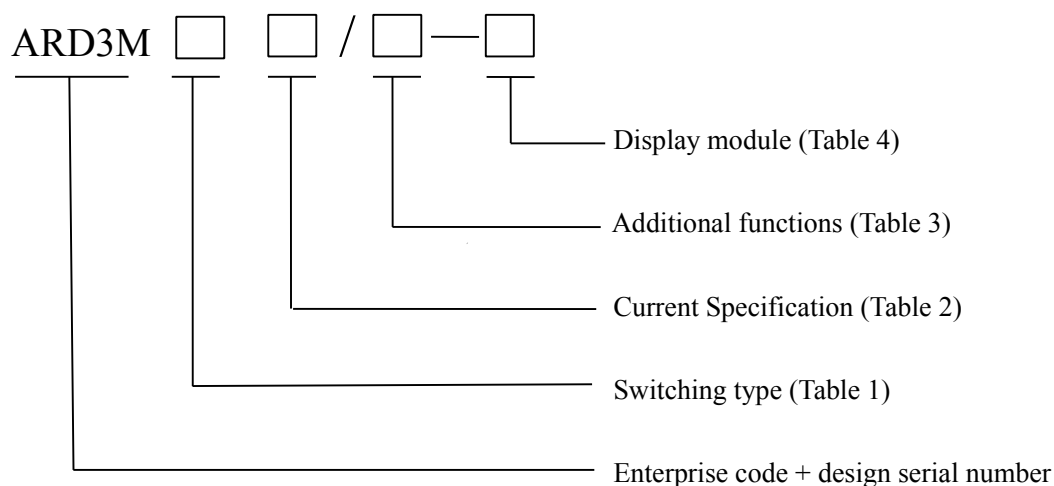

The standard switch quantity of ARD3M is 10DI and 6DO, and the switch quantity type is shown in Table 1:

Table 1

Main switch classification	Code
DI is the dry contact, and the external power supply of DO is AC220V	K1
DI is the wet contact, the input is DC110V, and the external power supply of DO is AC220V	K2
DI is the wet contact, the input is DC220V, and the external power supply of DO is AC220V	K3
DI is the wet contact, AC220V input, and DO external power supply is AC220V	K4

The correspond to relation between ARD3M current specification and the rated current and power of the applicable motor is shown in Table 2:

Table 2

Protector current specification (A)	Ratio setting	Primary side coil number of transformer	Applicable scope of motor (kW)	Suitable for motor Rated current range (A)
1	Support	5 circle	0.12-999	0.1-5000
5		1circle	0.12-999	0.5-5000
25	Does not support	1circle	3-11	6.3-25
100		1circle	15-45	25-100
250		1circle	55-132	63-250
800		1circle	160-250	250-800

Additional features of ARD3M are shown in Table 3:

Table 3

Additional function		Code	Additional function	Code
2-63 harmonic voltages and currents		H	Waveform recording	WR
Additional Communi cation module (Optional)	1channel PROFIBUS DPV1communication	CP	Anti - electric shock function	SU
	2 channel PROFIBUS DPV1communication	2CP	Insulation monitoring	Ri
	Ethernet communication (MODBUS TCP protocol)	MCE	Electric leakage protection	L
	1channel Profinet communication	PNET	Fault record	SR
1channel 4-20mA output		M1	2 channel 4-20mA output	M2
Wireless function (optional with color dot matrix LIQUID crystal)		WIFI		

See Table 4 for the ARD3M display module:

Table 4

Display module	code
Black and white dot matrix LCD, module size 98×60, opening 92×55 (unit mm)	60L1
Color dot matrix LCD, module size 98×60, cut-out 92× 55 (Unit mm)	60L2

Remarks:

(1) The auxiliary power supply defaults to AC 220V. If AC 380V auxiliary power is needed, please note the correspond to parameters when placing an order after communication with the manufacturer.

(2) The current specifications of 100A and below shall be the same type of current transformer. The transformer is equipped with a secondary line of about 1m. If you need special line length, please contact the manufacturer. The 250A and 800A current specifications use two other types of transformers with no secondary wires. See "External Dimensions and Installation" for the dimensions of the transformer

(3) The standard display cable is a network cable with a length of 1.5m. 3 meters and 5 meters are available for optional configuration. You can place an order and remark the correspond to cable length.

(4) For customers who do not need display modules, a batch of optional several display modules can be used as a programmer, or the configuration software provided by the manufacturer can be used to configure parameters through computer software.

(5) The temperature measurement support sensor type is PTC or NTC.

(6) After selecting the leakage function (L), each protector shall be equipped with a leakage transformer. Please refer to the "External Dimensions and Installation" section for the dimensions of the leakage transformer. The leakage transformer is equipped with a secondary wire of 2m±10cm. If other lengths are needed, please contact the manufacturer.

4 Main parameters

4.1 Technical indicators

ARD3M technical indicators are shown in Table 5:

Table 5

Technical parameters	Technical indicators	
Protector auxiliary power supply	Support two power modules, AC 220V power module (AC85-265V/DC100-300V) default, AC 380V power module (AC/DC 100-415V) optional	
Rated working voltage of the motor	AC220V / 380V / 660V, 50Hz / 60Hz	
Rated operating current of the motor	1 (0.1A-5000A)	External current transformer
	5 (0.1A-5000A)	
	25 (6.3A-25A)	
	100 (25A-100A)	
	250 (63A-250A)	
	800 (250A-800A)	
Relay output contact capacity	Impedance load	AC250V、10A
Switching input	10 channels of passive dry contact (active DC110V, DC220V, AC220V input can be optional)	
Communication	Standard supplied	2channel MODBUS RTU communication
	Optional (only one can be selected)	1-2 channel PROFIBUS DPV1communication、1channel PROFINET communication、Ethernet communication (MODBUS TCP protocol)
Environment	Working temperature	-10°C~55°C
	Storage temperature	-25°C~70°C
	Relative humidity	≤95% No condensation, no corrosive gas
	Altitude	≤2000m
Pollution levels	Class 3	
Protection grade	Main body IP20, split display module IP54 (installed on the cabinet panel)	
Installation category	Level III	

4.2 Functional configuration

The ARD3M functional configuration is shown in Table 6

Table 6

Function	Type	Functional configuration	
		Standard function	Optional function
Protection function	Fixed time overload	√	
	Inverse time overload	√	
	Starting timeout	√	
	Phase loss	√	
	Voltage unbalance	√	
	Current unbalance	√	
	Locked-rotor	√	
	under load	√	

	External fault	√		
	Block	√		
	Temperature protection (PTC/NTC)	√		
	Residual current	grounding	√	
		leakage		√ (leakage)
	Phase sequence	√		
	Under voltage	√		
	Over voltage	√		
	Under power	√		
	Over power	√		
	tE Time protect	√		
	Overflow protection	√		
	Alarm of starting times	√		
	Running time alarm	√		
	Fault frequency alarm	√		
Control mode	Protect type	√		
	Manual mode			
	Two step model			
	Double speed mode			
	Star triangle three successive			
	Power Shake and start again		√	
Communication function	2channel Modbus-RTU communication	√		
	1-2channel PROFIBUS DPV1 communication		√	
	1channel PROFINET communication		√	
	1-channel Ethernet communication (dual network port)		√	
	WIFI function		√(Optional with color dot matrix LIQUID crystal)	
Switching input	10 DI	√		
Relay output	6 DO	√		
Analog output	1channel DC4-20mA		√	
	2channe DC4-20mA			
Event log	Start record,stop record,DI displacement record,restart record,operation record (support communication transmission and U disk export)		√	
Waveform recording	Record the current,voltage,DI/DO waveform before and after the fault trip,support communication transmission and U disk export		√	

Measurement display constant value setting	Measured parameters	Three phase current,three phase line voltage,active power,reactive power,power factor,frequency,active power,reactive power,etc	√	
		2-63rd current,voltage harmonics,harmonic inclusion rate,total harmonic distortion rate		√
	Fixed value setting	Various protected fixed value queries	√	
		Various protection Settings	√	
Display unit	Liquid crystal display (LCD)	Black and white dot matrix LCD display		√
		Color dot matrix LIQUID crystal display		

5 Overall dimensions and installation

The product composition of ARD3M is shown in Figure 1, Figure 2 and Figure

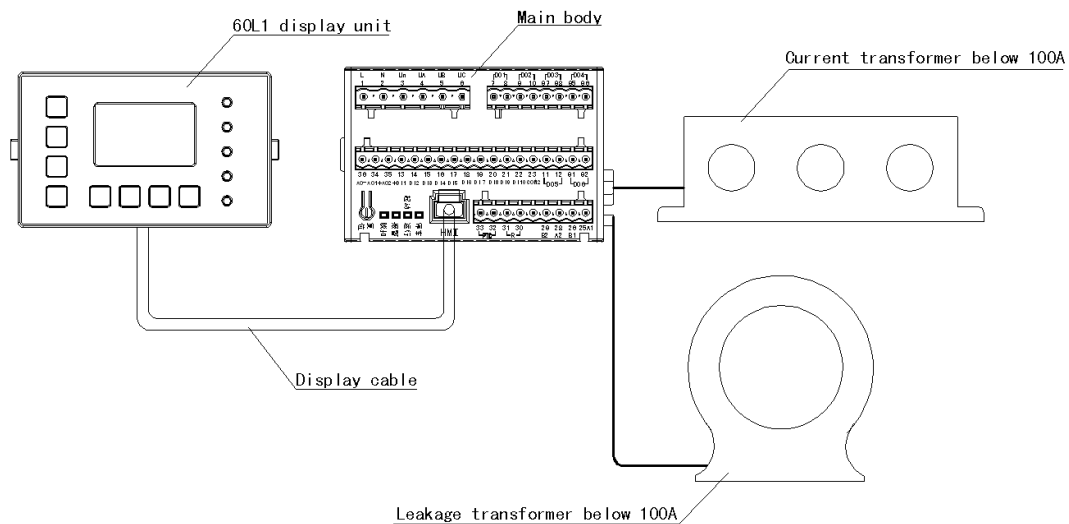

FIG. 1 Composition of products with 100A and below specifications

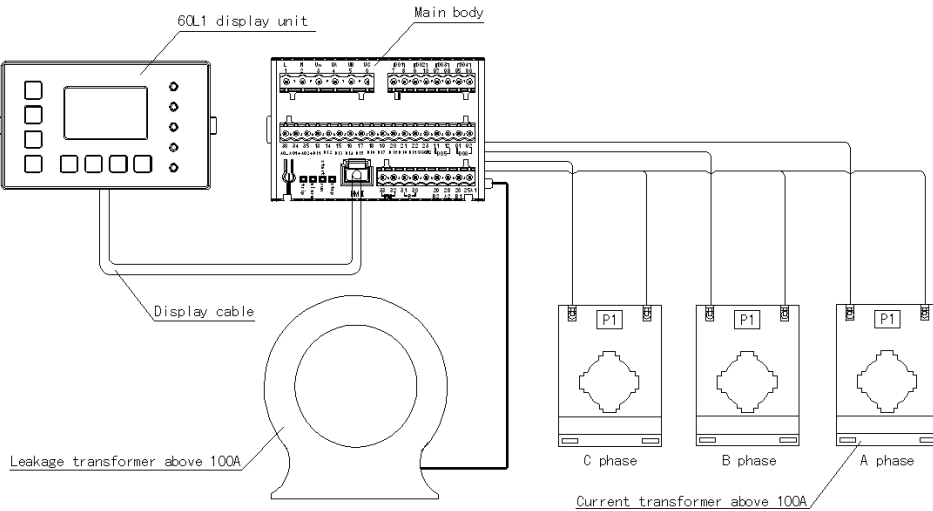

FIG. 2 Composition of 250A and 800A

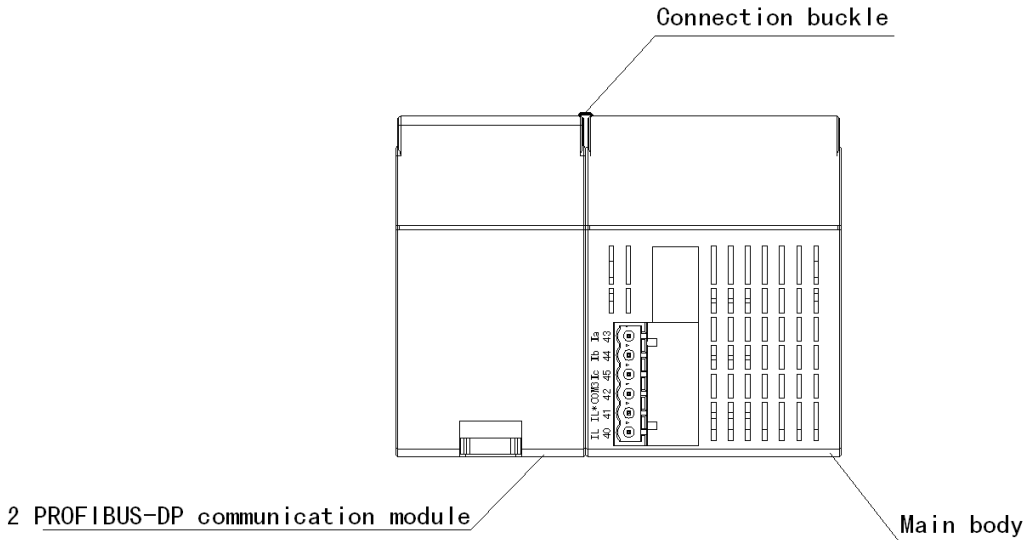
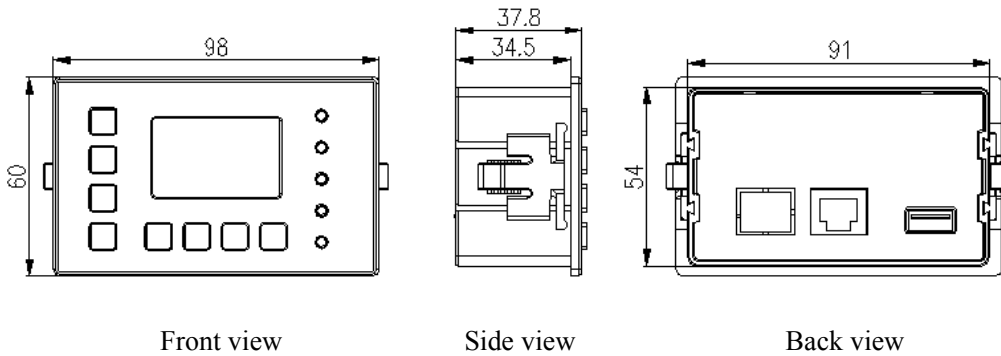

FIG. 3 Assembly diagram of main body and optional communication module

Note: When a single channel PROFIBUS_DP, Ethernet or PROFINET communication module is selected, its combination with the main body is the same as that shown in Figure 3.

5.1 Panel size and opening (Unit:mm)

5.1.1 60L1 The shape and opening size of the black and white LIQUID crystal display unit are shown in Figure 4:



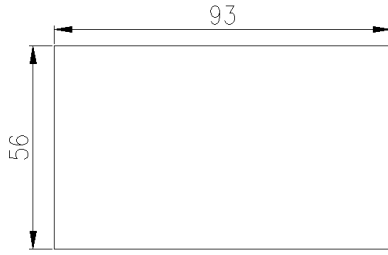

Disk cut-out size

Figure 4 60L1 shows the unit shape and hole size

5.1.2 The external dimensions of 60L2 color LIQUID crystal display unit are shown in Figure 5 (the dimensions of side view, rear view and opening are the same as those of 60L1 black and white liquid crystal display unit) :

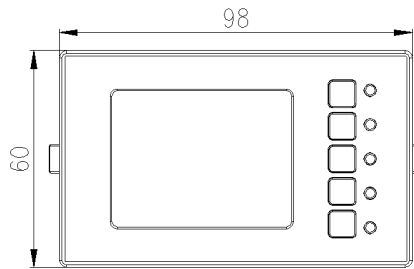
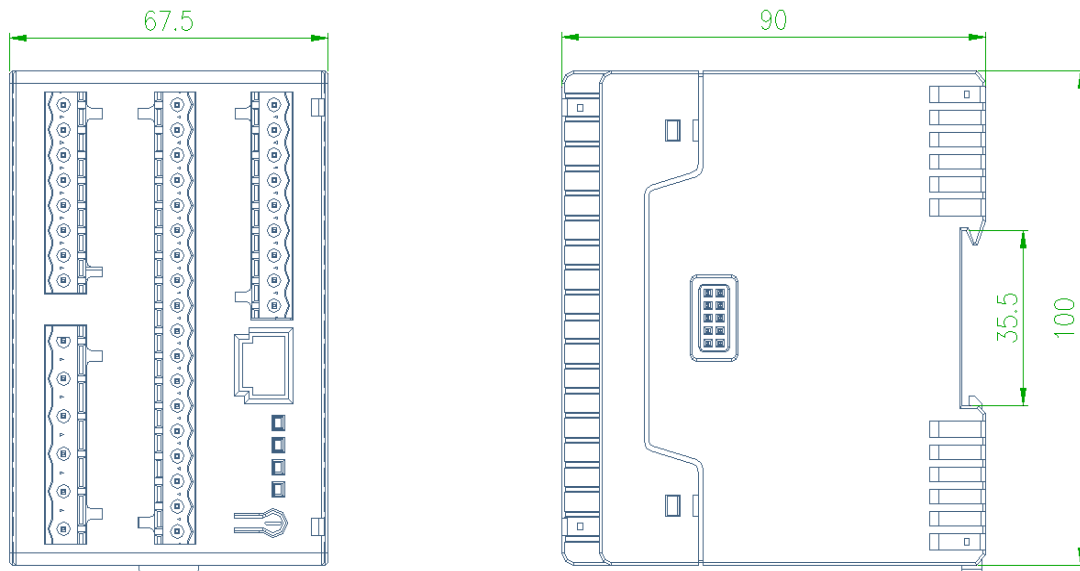

Figure 5 60L2 shows the external dimensions of the unit

5.2 Size of main and additional Communication module (unit: mm)

5.2.1 The ARD3M main body is installed with 35mm guide rail, and its external dimensions are shown in Figure 6:



Front view

Side view

Figure 6 ARD3M main body dimensions

5.2.2 The external dimensions of PROFINET communication module, single-channel PROFIBUS_DP communication module and Ethernet communication module are shown in Figure 7. Each communication module is installed with guide rail:

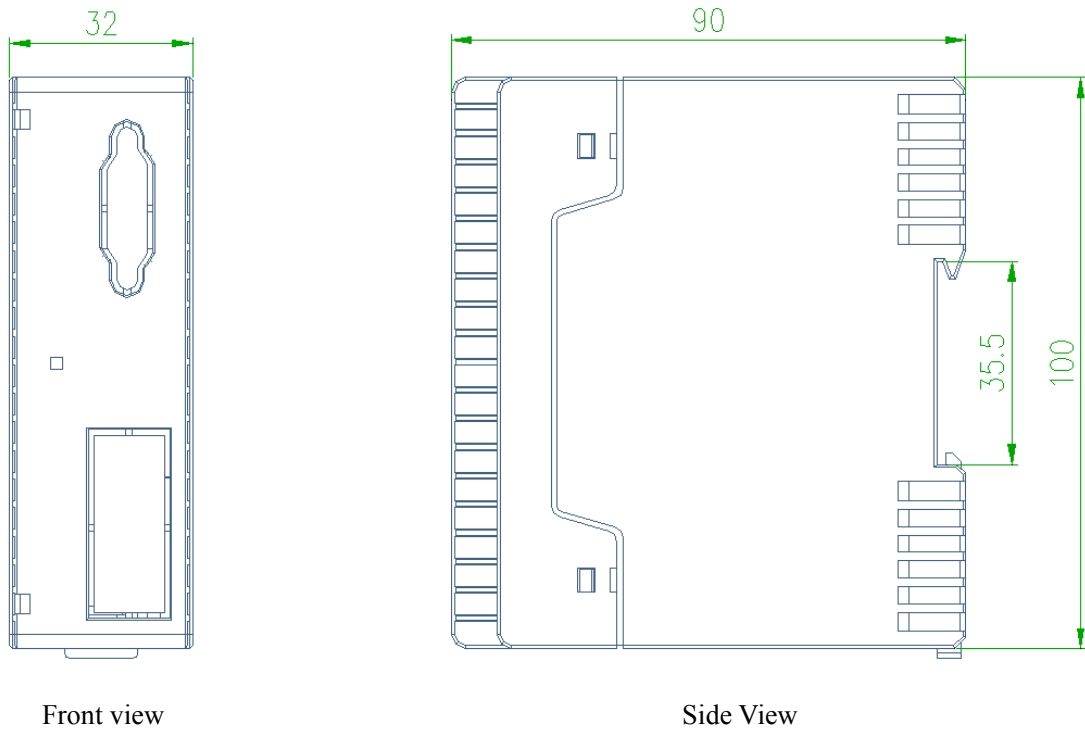

Figure 7 Overall dimensions of PROFINET, single-channel PROFIBUS_DP and Ethernet communication module

5.2.3 The size of the dual-channel PROFIBUS_DP communication module is shown in Figure 8. The module is installed with guide rail:

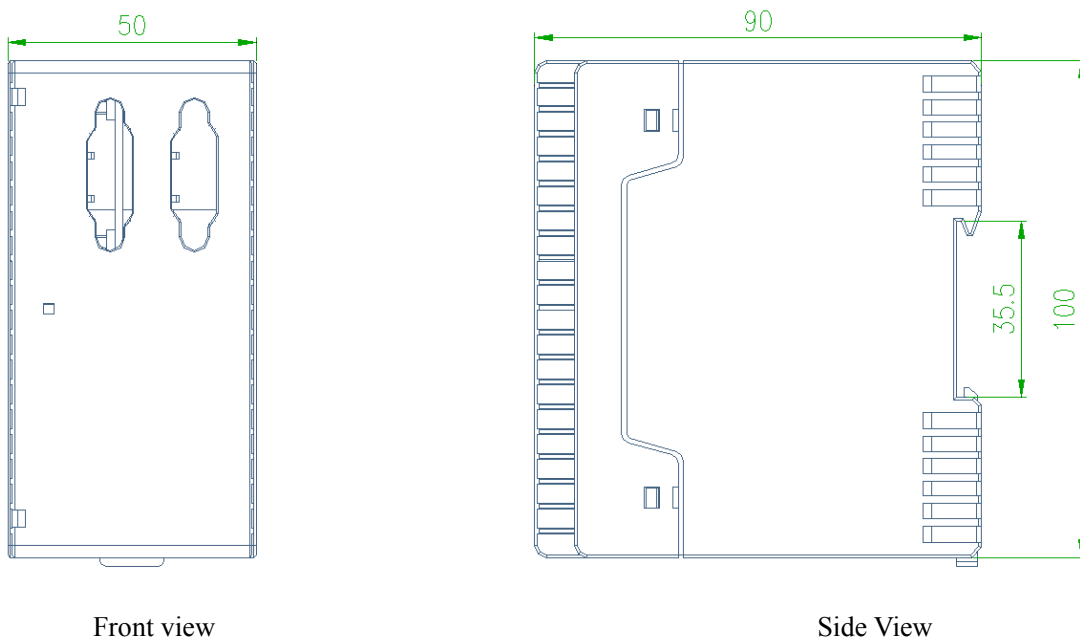

Figure 8 External dimensions of 2-channel PROFIBUS_DP communication module

5.3 Transformer size

5.3.1 The external dimensions of current transformers of 100A and the following specifications are shown in FIG. 9 (unit: mm) ::

The current transformer with the current specification of the protector is 100A, with the standard secondary connection line length of 1m±10cm. If other lengths are needed, please contact the

manufacturer, for example, 3m and 5m lines are optional. The secondary lines of yellow, blue, red and black correspond to the correlation of current A, B, C and the common end of the transformer. A protector is equipped with A set of transformer.

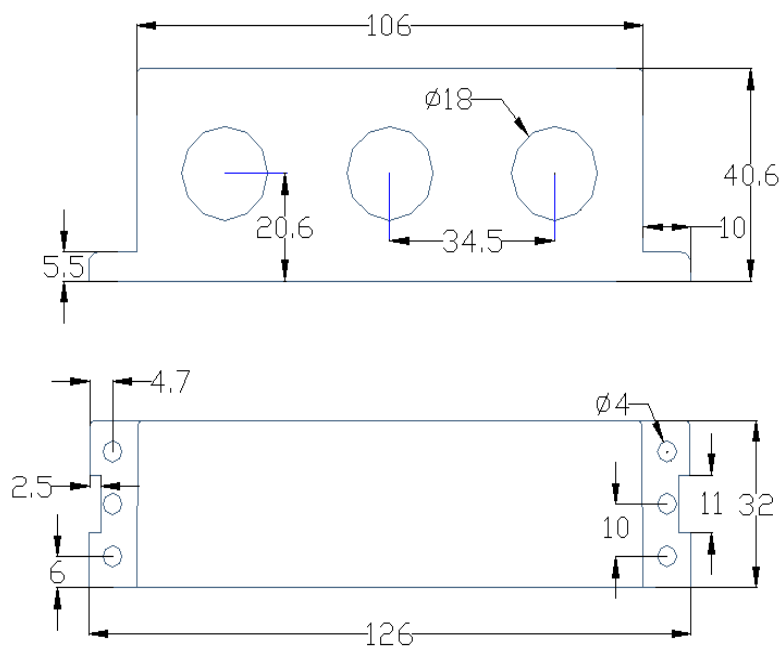

FIG. 9 External dimensions of current transformers with specifications below 100A

5.3.2 The external dimensions of the 250A current transformer are shown in FIG. 10 (unit: mm) : The current specification of the protector is the current transformer matched at 250A. There is no secondary connection wire. One protector is equipped with three transformers.

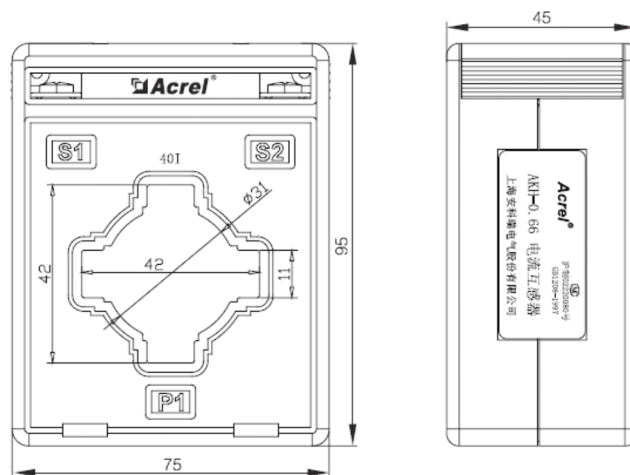

FIG. 10 External dimensions of current transformer 250A

5.3.3 The external dimensions of the current transformer (800A) are shown in FIG. 11 (unit: mm) : The current specification of the protector is 800A and the current transformer is not equipped with secondary connection. One protector is equipped with three transformers.

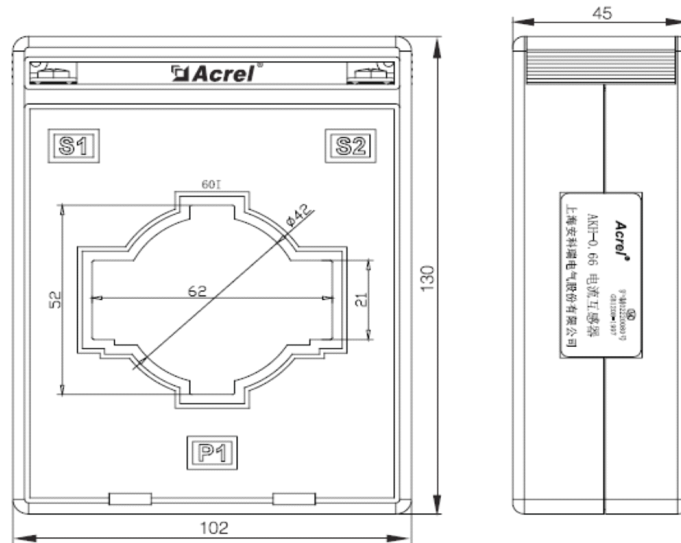

FIG. 11 External dimensions of current transformer 800A

5.3.4 The external dimensions of the leakage current transformer are shown in Figure 12 and Table 7 (unit: mm) :

The protectors with current specifications of 100A and below are equipped with leakage current transformers with specifications of L-45.250A and current protector with specifications L-80 leakage current transformer;800A and current specification protector with L-150 leakage current transformer.The leakage transformer is equipped with a secondary wire of 2m±10cm. If other lengths are needed, please contact the manufacturer.

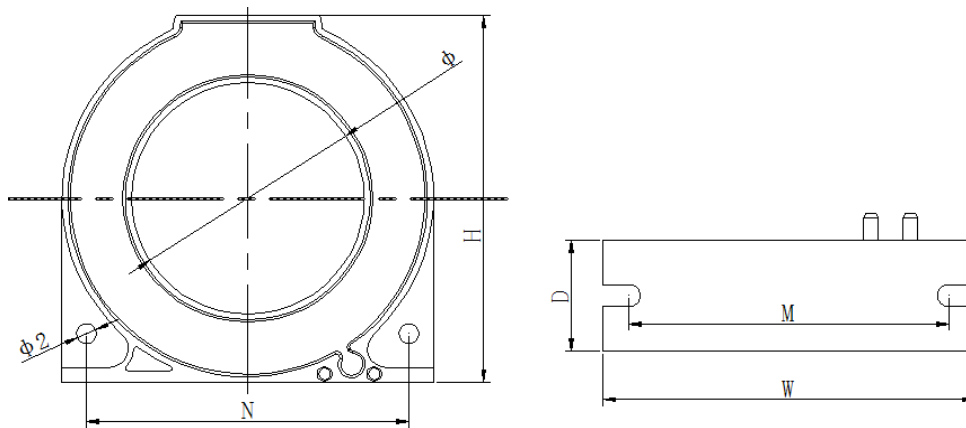

FIG. 12 External dimensions of leakage current transformer

Table 7

Type Spec	Overall size(mm)			Go through size(mm)	Installation size(mm)			Tolerance(mm)	Weight (g)
	W	H	D	Φ	M	N	Φ2		
L-45	75	75	22	46	65	65	4	±1	200±10
L-80	120	120	23	81	105	105	4		380±20
L-150	196	205	24	150	175	180	6		850±50

5.4 Terminal

5	Ub Phase voltage input	6-channel programmable relay output (DO) (The function is defined as factory default setting, which can be set by users according to their needs)
6	Uc Phase voltage input	
7、8	DO1, Start 1 output	
9、10	DO2, Start 2 output	
97、98	DO3, Trip output, normally open point signal	
95、96	DO4, Trip output, normally closed signal	
11、12	DO5, Circuit breaker output	10-channel programmable Switching input (DI) (The function is defined as factory default setting, which can be set by users according to their needs)
91、92	DO6, Alarm output	
13	DI1, Start 1 signal input	
14	DI2, Start 2 signal input	
15	DI3, Stop signal input	
16	DI4, Reset signal input	
17	DI5, Emergency stop signal input	
18	DI6, External fault signal input	
19	DI7, Control permission 1 input	
20	DI8, Control permission 2 input	
21	DI9, ordinary DI	2-channel 4-20mA analog output
22	DI10, ordinary DI	
23	COM2, DI Input common terminal	
34	The first analog output AO1+	2-channel 4-20mA analog output
35	The second analog output AO2+	
36	Analog output common end AO-	
25	A1	first channel MODBUS communication
26	B1	second channel MODBUS communication
28	A2	
29	B2	Insulation resistance detection
30、31	R	
32	T1 (PTC input A)	Temperature protection (thermistor input)
33	T2 (PTC input B)	
40	IL*	Leakage current measurement
41	IL	
42	COM3(current enters the common terminal)	Three phase current input
43	Ia Phase current input	
44	Ib Phase current input	
45	Ic Phase current input	

6 Protection function description

The default action stages of each protection are shown in Table 9:

Table 9

Protection type	Default active period
-----------------	-----------------------

Overvoltage, undervoltage, voltage imbalance, phase sequence, external fault, overflow protection, starting times, fault times, running time, PTC/NTC temperature protection, insulation monitoring	whole course
Reverse time overload, blocking, phase break, leakage, grounding, starting timeout, short circuit, overflow protection, Overvoltage, undervoltage, voltage imbalance, phase sequence, external fault, number of starts, number of faults, running time, PTC/NTC temperature protection, fixed time overload, insulation monitoring	When starting
Reverse time-limit overload, blocking, phase break, current imbalance, leakage, grounding, constant time-limit overload, under load, short circuit, overflow protection, overvoltage, undervoltage, voltage unbalance, phase sequence, underpower, overpower, external fault, PTC/NTC temperature protection, number of starts, number of faults, running time, insulation monitoring	In operation

6.1 Inverse time overload protection

When the motor runs for a long time in excess of its rated current under excessive load, it will overheat the motor, reduce insulation and burn it out. The protector calculates the heat capacity of the motor according to its heating characteristics and simulates its heating characteristics to protect the motor.

The starting condition of reverse time-limit overload protection is that the maximum three-phase current reaches the set overload starting value, and the default overload starting value is 1.2 times the motor's rated current.

The current-time comparison table of overload protection is shown in Table 10, and the overload characteristic curve (K curve) is shown in Figure 14:

Table 10

Optional tripping curve grade K	1	2	3	5	10	15	20	25	30	35	40
Tripping delay (S) tolerance $\pm 10\%$	Three - phase balanced load, starting from the cold state										
Rated value $I_e \times 1.2$	25	50	75	125	250	375	500	625	750	875	1000
$\times 1.5$	16	32	48	80	160	240	320	400	480	560	640
$\times 2$	9	18	27	45	90	135	180	225	270	315	360
$\times 3$	4	8	12	20	40	60	80	100	120	140	160
$\times 4$	2.26	4.52	6.78	11.3	22.5	33.8	45	56.3	67.5	78.8	90
$\times 5$	1.44	2.88	4.32	7.2	14.4	21.6	28.8	36	43.2	50.4	57.6
$\times 6$	1	2	3	5	10	15	20	25	30	35	40
$\times 7.2$	0.7	1.4	2.1	3.5	6.9	10.4	13.9	17.4	20.8	24.3	27.8

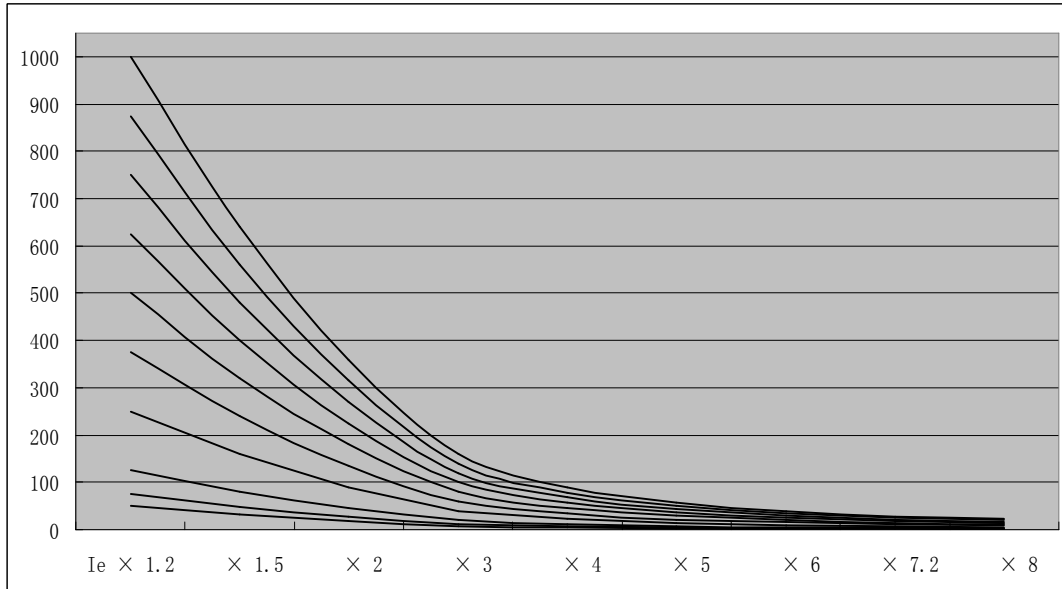
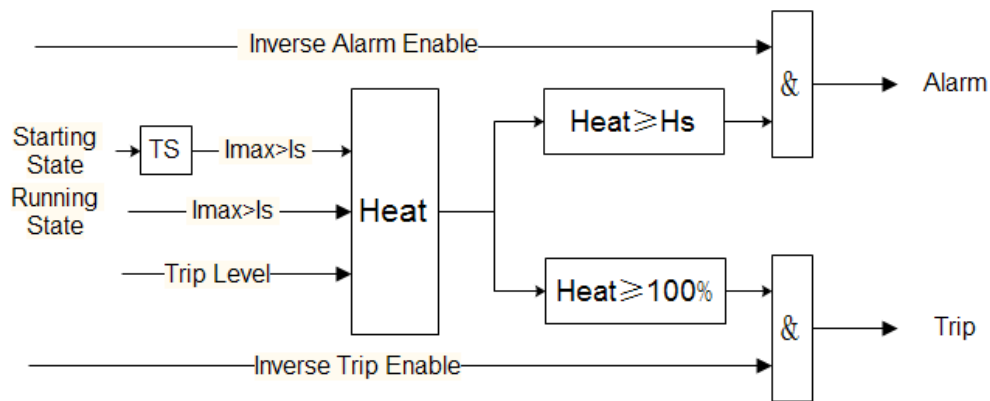

FIG. 14 Characteristic curve of overload (K curve)

Inverse time overload protection improves manual and automatic reset options. When "automatic" is selected, after the overload trip of the motor, the heat capacity will be automatically reset to less than 15%, and the restart operation can be allowed without the need for further reset operation; When "manual" is selected, after the motor overload trip, the heat capacity will be reduced to less than 15%. Manual manual reset is required, otherwise the restart operation is not allowed.



Note:

I_{max} : Maximum three-phase current

I_n : Rated current

Heat: Percentage heat capacity

H_s : Heat capacity alarm value

6.2 Start overtime protection

When the starting time of the motor reaches the starting time set by the user, the average three-phase current does not drop below the set tripping threshold, trigger the starting timeout protection, issue tripping command, and stop the motor operation. For the increased safety motor, the starting time setting shall not exceed 1.7 times t_E time.

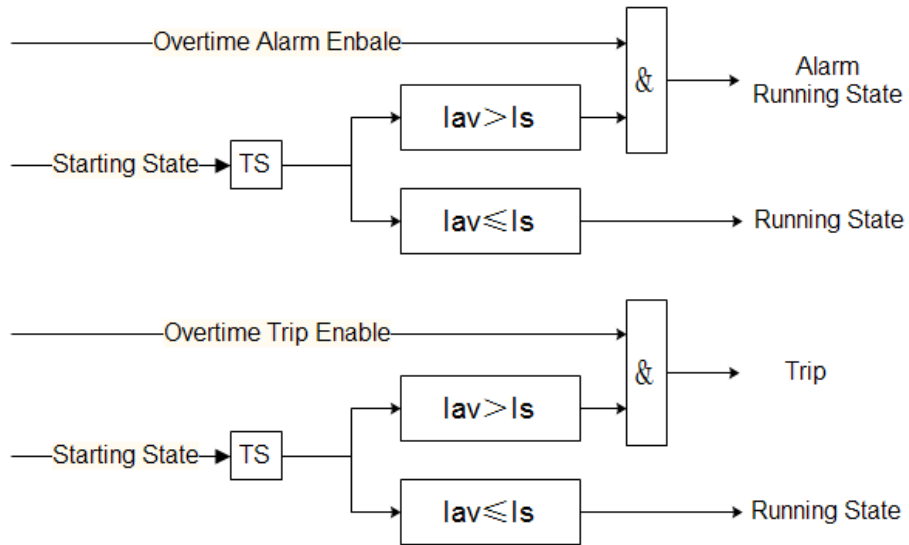

Note:

Iav: Three-phase mean current

Is: Set trip threshold

Ts: Starting time

6.3 Locked-rotor protection

In the process of starting, if the motor shaft is stuck due to excessive load or mechanical reasons, and the fault is not removed in time, the motor will overheat and the insulation will be reduced and the motor will be burned out. The locked-rotor protection is applicable to the motor when such faults occur in the starting stage. When the average current percentage reaches the set threshold, the protector will trip or alarm within the set time in time to avoid the motor burning out.

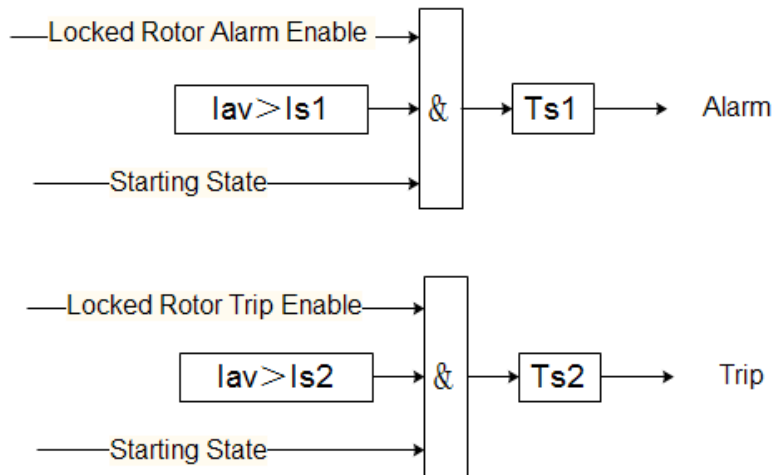

Note:

Iav: Three-phase mean current

Is1: Alarm action threshold

Is2: Tripping threshold

Ts1: Alarm action delay time

Ts2: Delay time of trip action

6.4 Blocking protection

During the operation of the motor, if the motor shaft is stuck due to excessive load or mechanical reasons, and the fault is not removed in time, the motor will be overheated and the insulation will be reduced and the motor will be burned out. The blocking protection is applicable to protect the motor when such faults occur in the running stage. When the average current reaches the set threshold, the protector will trip or alarm within the set time in time to avoid the motor burning out.

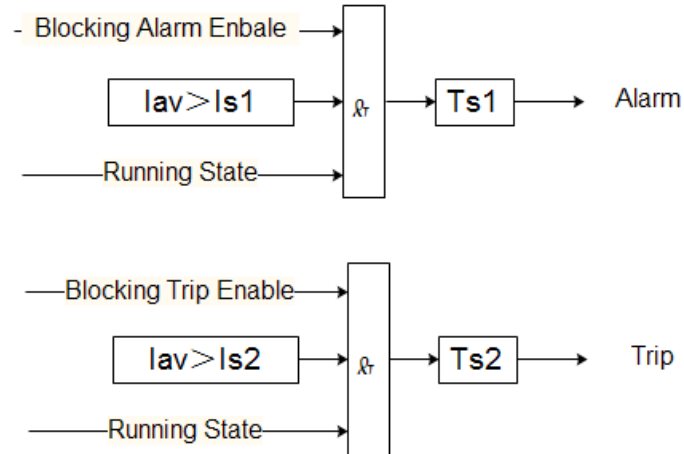

Note:

Iav: Three-phase mean current

Is1: Alarm action threshold

Is2: Tripping threshold

Ts: Alarm action delay time

6.5 under load protection

The protector provides under load protection when the motor is loaded with pumping load. When the average three-phase current is lower than the set value, the protector should trip or alarm within the set time.

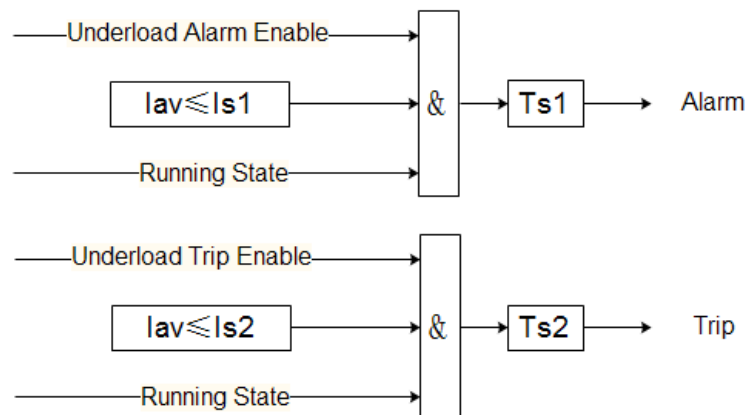

Note:

Iav: Three-phase mean current

Is1: Alarm action threshold

Is2: Tripping threshold

Ts1: Delay time of alarm action

Ts2: Delay time of trip action

6.6、 Underpower protection

When the load power is lower than the set action value, the protector will trip or alarm during the set action time.

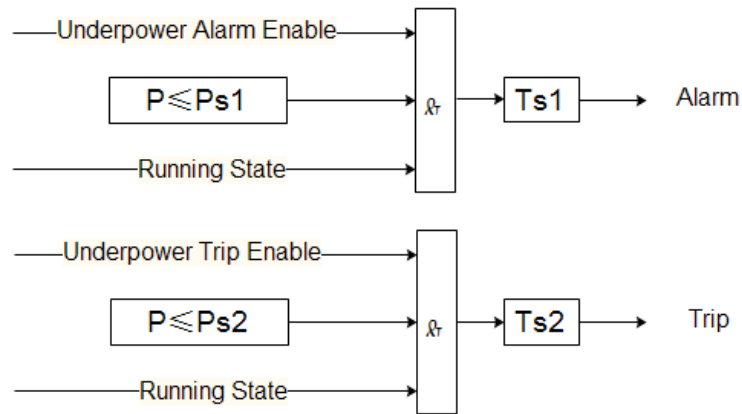

Note:

P: Total active power

Ps1: Alarm action threshold

Ps2: Trip action threshold

Ts1: Delay time of alarm action

Ts2: Delay time of trip action

6.7 Overload protection

In addition to reverse Overload protection, the protector can also provide time-limit overload protection. When the percentage of three-phase average current and rated current is greater than the set value, the protector should trip or alarm within the set time.

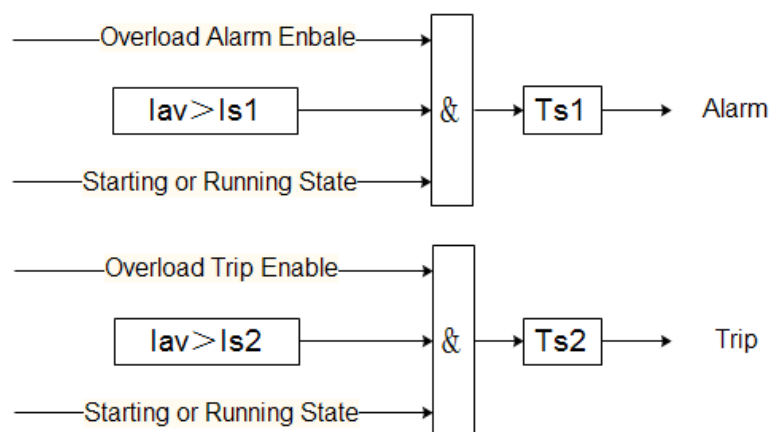

Note:

I_{av}: Three-phase mean current

I_{s1}: Alarm action threshold

I_{s2}: Tripping threshold

Ts1: Delay time of alarm action

Ts2: Delay time of trip action

6.8 Overpower protection

When the percentage of load power to rated power is greater than the set action value, the protector will trip or alarm during the set action time.

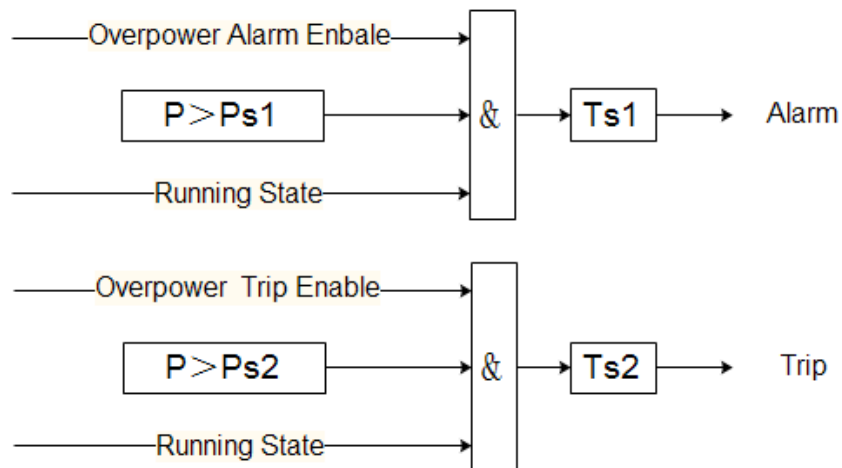

Note:

P: Total active power

Ps1: Alarm action threshold

Ps2: Trip action threshold

Ts1: Delay time of alarm action

Ts2: Delay time of trip action

6.9 Ground fault protection

The protector is protected by the ground current according to the three-phase current vector and the calculation of the ground current. The grounding protection can set the starting shielding time. After the starting shielding time, when the grounding current is greater than the set value, the action logic can choose the breaker or breaker or alarm. When the breaker is chosen, the protector should first switch the breaker and then switch the contactor after 200ms

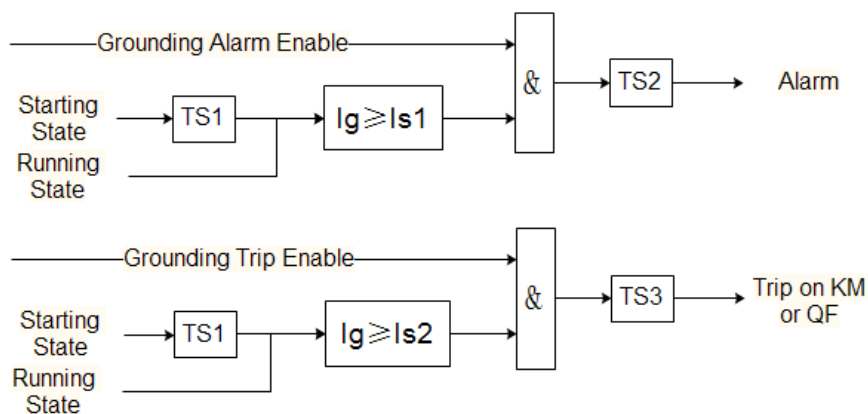

Note:

Ig: Ground current

Is1: Alarm action threshold

Is2: Tripping threshold

Ts1: grounding start shielding time

Ts2: Delay time of alarm action

Ts3: Delay time of trip action

6.10 Leakage protection

Leakage protection should be equipped with leakage current transformer, which can detect the leakage current through the zero-sequence transformer. The leakage protection can set the starting shielding time. After the starting shielding time, when the leakage current is greater than the set value, the operation logic can choose the breaker or breaker or alarm. When the breaker is chosen, the protector should first switch the breaker and then the breaker after 200ms.

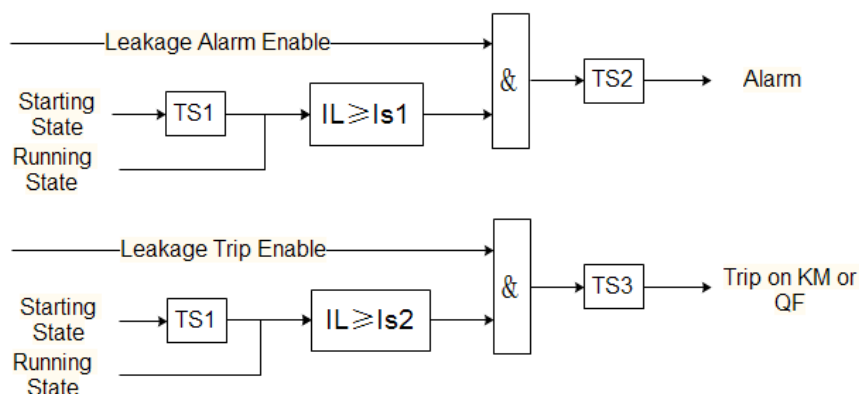

Note:

IL: Leakage current

Is1: Alarm action threshold

Is2: Tripping threshold

Ts1: Shield time for leakage starting

Ts2: Delay time of alarm action

Ts3: Delay time of trip action

6.11 I unbalance protection

The protector calculates the current imbalance degree. When the three-phase current imbalance degree is greater than the set value, it will trip or alarm within the set time. The calculation formula of current imbalance degree is as follows:

$$I_{uf} = \left| \frac{I_{\max(\min)} - I_{av}}{I_{av}} \right| \times 100\%$$

I_{uf} is the current imbalance, I_{\max} is the maximum current, I_{\min} is the minimum current, and I_{av} is the average current.

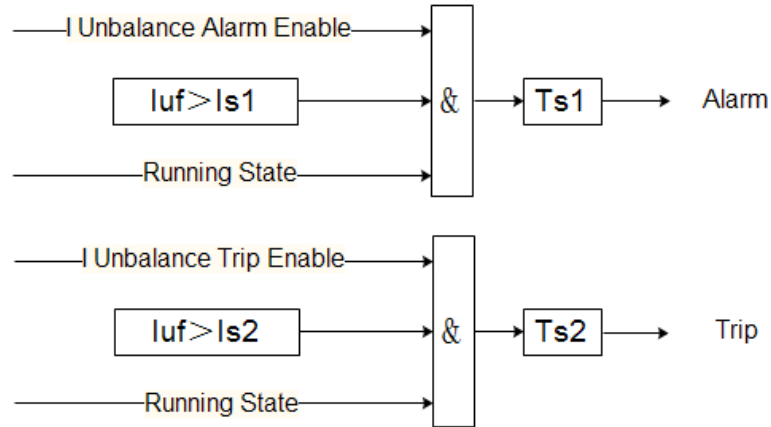

Note:

Iuf: Degree of current imbalance

Is1: Alarm action threshold

Is2: Tripping threshold

Ts1: Delay time of alarm action

Ts2: Delay time of trip action

6.12 U unbalance protection

The protector calculates the voltage unbalance. When the voltage unbalance is greater than the set value, it will trip or alarm within the set time. The calculation formula of voltage imbalance is as follows:

$$U_{uf} = \left| \frac{U_{\max(\min)} - U_{av}}{U_{av}} \right| \times 100\%$$

U_{uf} is the voltage imbalance, U_{\max} is the maximum line voltage, U_{\min} is the minimum line voltage, and U_{av} is the average line voltage.

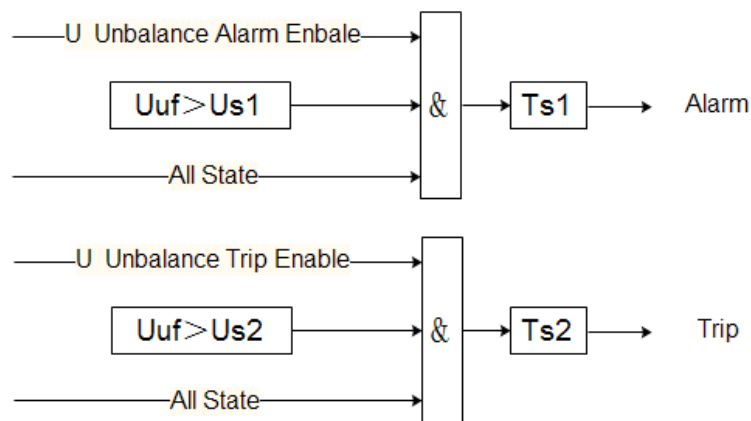

Note:

Uuf: Voltage imbalance degree

Us1: Alarm action threshold

Us2: Trip action threshold

Ts1: Delay time of alarm action

Ts2: Delay time of trip action

6.13 Phase fail protection

When the phase fault runs, it will do great harm to the motor. When the maximum current is greater than 20% rated current and the minimum current is less than 5% rated current, or when the imbalance degree of three-phase current is greater than 30%, the fault protection will trip or alarm within the set time.

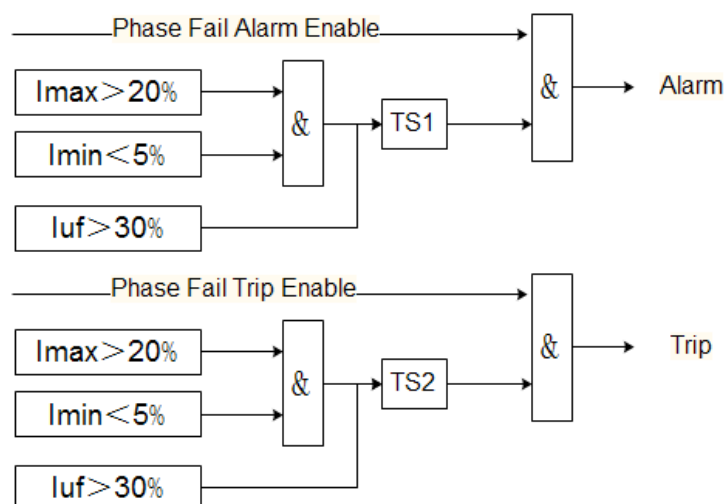

Note:

Imax: Maximum current

Imin: Minimum current

Iuf: Degree of current imbalance

Ts1: Delay time of alarm action

Ts2: Delay time of trip action

6.14 Phase sequence protection

When the error of three-phase voltage phase sequence is detected, the protector will trip or alarm within the set time to protect the safety of the motor.

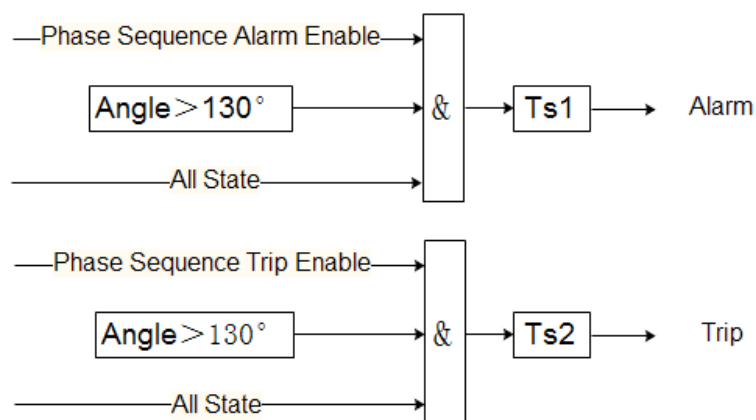

Note:

Angle: The Angle between any two - phase voltage

Ts1: Delay time of alarm action

Ts2: Delay time of trip action

6.15 Overvoltage protection

Excessive voltage will cause damage to the insulation of the motor. When the maximum line voltage of the motor exceeds the set value, the protector will trip or alarm within the set time.

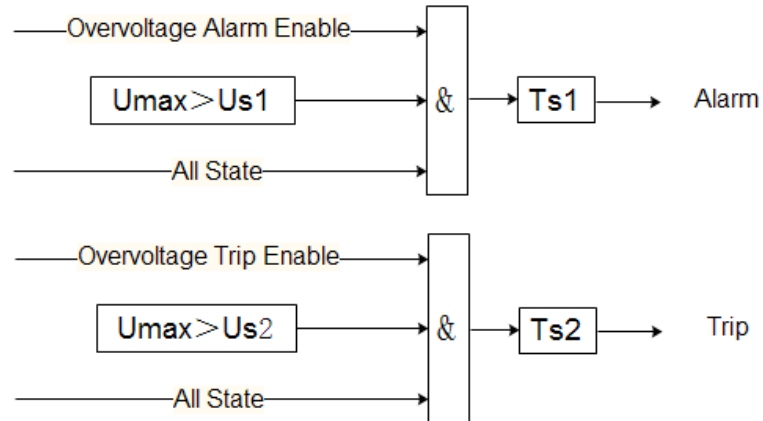

Note:

U_{max} : Maximum line voltage

U_{s1} : Alarm action threshold

U_{s2} : Trip action threshold

Ts1: Delay time of alarm action

Ts2: Delay time of trip action

6.16 Undervoltage protection

Too low voltage will cause the motor to slow down, or even stop running. When the minimum line voltage of the motor is lower than the set value, the protector will trip or alarm within the set time.

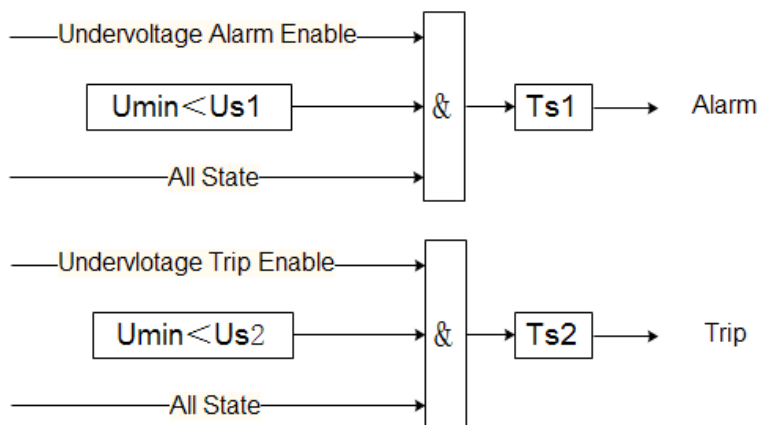

Note:

U_{min} : Minimum line voltage

U_{s1} : Alarm action threshold

U_{s2} : Trip action threshold

Ts1: Delay time of alarm action

Ts2: Delay time of trip action

6.17 Short circuit protection

When the motor current exceeds the set value, the protector will switch circuit breaker or alarm within the set time. The short circuit protection is divided into two stages: starting and running. The protection parameters of the two stages can be set independently.

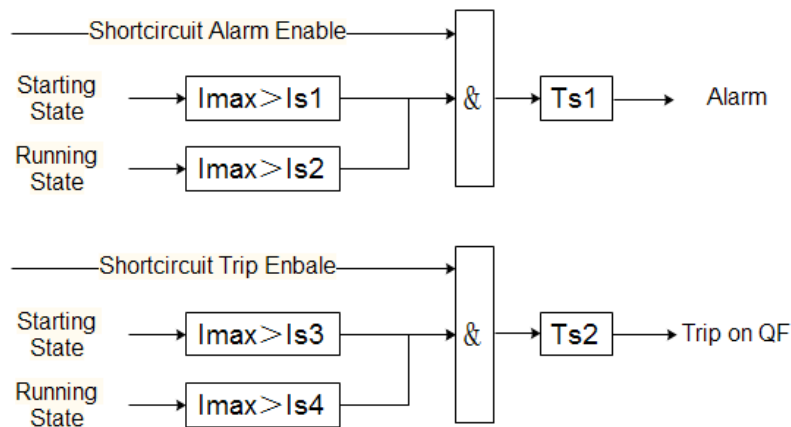

Note:

I_{max} : Maximum current

I_{s1} : Threshold of short circuit alarm during starting stage

I_{s2} : Threshold of short circuit alarm during operation

I_{s3} : Threshold of short-circuit trip during starting stage

I_{s4} : Threshold of short-circuit trip during operation

T_{s1} : Delay time of alarm action

T_{s2} : Delay time of trip action

6.18 Temperature protection

Temperature protection is based on the thermistor resistance embedded in the stator windings or bearings of the motor. According to the type of thermistor selected, the protection logic is different: when the thermistor is PTC, when the detected resistance value is greater than the set value, the protector will trip or alarm within the set time; When the thermistor is NTC, when the detected resistance value is less than the set value, the protector will trip or alarm within the set time

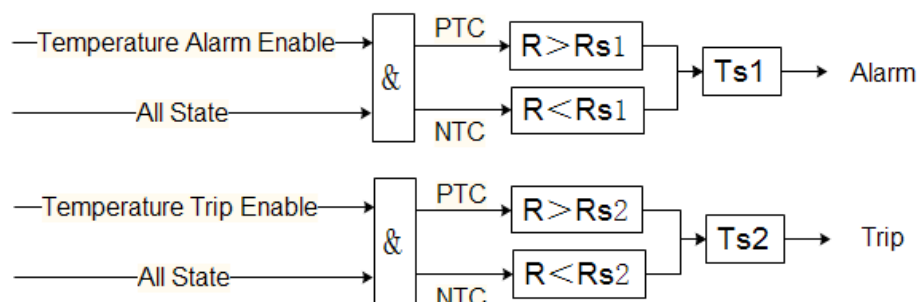

Note:

R : Check the temperature resistance

R_{s1} : Alarm action temperature resistance value

R_{s2} : Resistance value of tripping action temperature

T_{s1} : Delay time of alarm action

T_{s2} : Delay time of trip action

The temperature protection can be reset manually or automatically. When "Automatic" is selected, the protector will reset automatically after the temperature protection trip when the resistance value is detected to be less than the set return resistance value. When "manual" is selected, after the temperature protection trip, if the resistance value is detected to be less than the set return resistance value, manual manual reset is required, otherwise it will not be allowed to start again.

6.19 External fault

When the input of switch quantity defined as external fault is set as "normally on", the closing signal is taken as the trigger condition of the fault. When the duration of the fault signal is longer than the set tripping/alarm delay time, tripping/alarm will be generated. When the input of switch quantity defined as external fault is set as "normally closed", the disconnect signal is used as the trigger condition of the fault. When the duration of the fault signal is longer than the set trip/alarm delay time, trip/alarm will be generated.

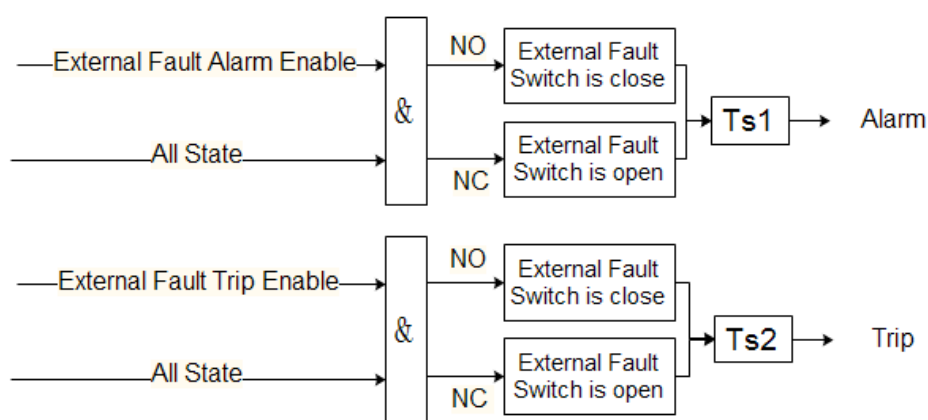

Note:

Ts1: Delay time of alarm action

Ts2: Delay time of trip action

6.20 Overflow protection

When the fault occurs, the current exceeds the breaking current of the contactor, and the contactor will be damaged if the contactor is forcibly disconnected. At this point, the breaker should be broken first, and then disconnect the contactor after the fault current is removed.

If the fault current of the protector is greater than the set overflow current before any other tripping fault action, the breaker should be first switched on, and then the contactor should be switched off after 200ms.

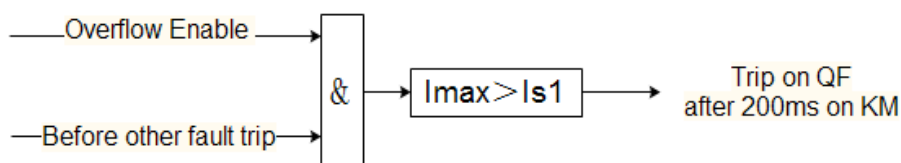

Note:

Imax: Maximum current

Is1: Overflow current

6.21 Number of starts protection

The motor is easy to be damaged due to frequent starting and cutting in a short time. When the remaining starting number of the motor is 0 within the set time, the protector sends an alarm signal. If the starting command is issued again at this time, the protector will release and allow to start again after the cooling time.

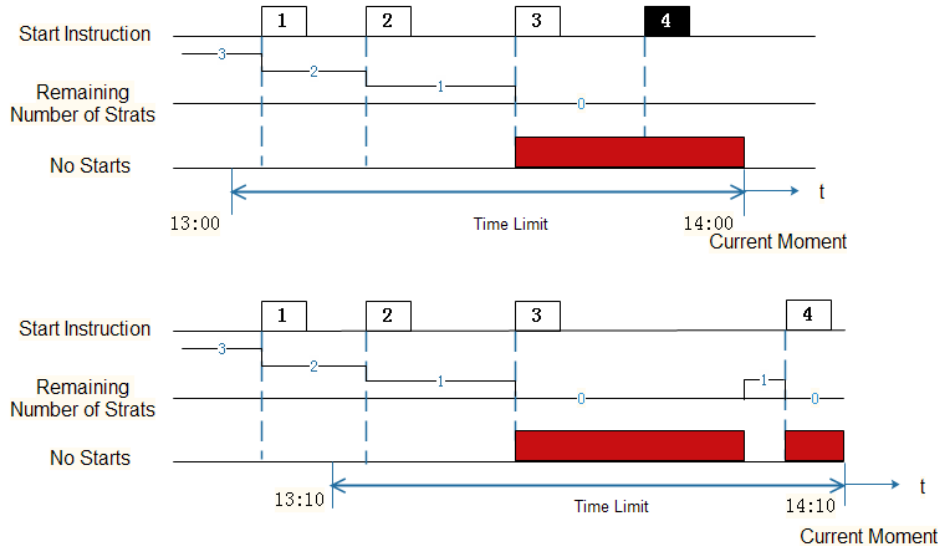

Example: Set the time limit of 1 hour to allow 3 starts.

Figure above: It has been started for 3 times between 13:00 and 14:00, and there is no number of starts at the fourth time, so the fourth time fails.

Figure below: Before the fourth start, the remaining number of starts is restored to 1, so the fourth start is successful.

6.22 Insulation fault protection

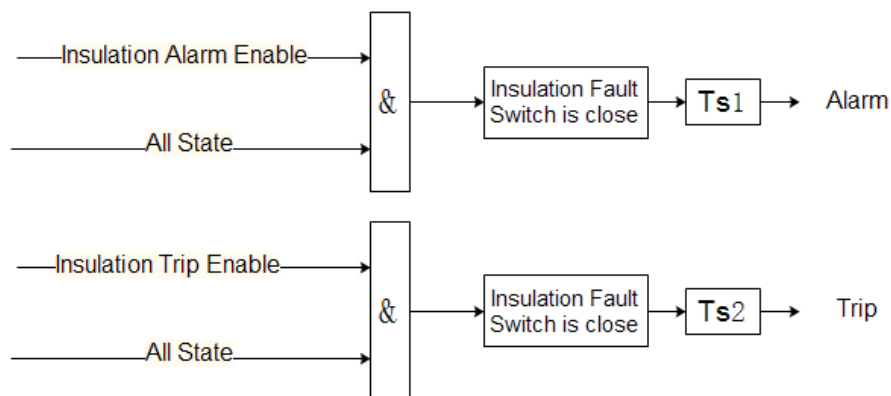

6.23 Running time alarm

When the accumulated running time of the motor exceeds the set value, the protector will send an alarm signal to remind the staff to overhaul and maintain the motor.

6.24 Fault frequency alarm

When the cumulative number of protection trips exceeds the set value, the protector will send an alarm signal.

7、 Function setting and description

7.1 Key of main module and LED indicator light are shown in Table 11:

Table 11

Serial No.	Name	State	Function Description
1	Stop LED indicator light	bright	The indicator light indicates that the motor is in a stopped state
2	Start/run indicator light	bright	The indicator light flashes to indicate that the motor is in the starting state, and is always on to indicate that the motor is in the running state
3	Alarm LED indicator light	bright	The light indicates an alarm
4	Trip LED indicator light	bright	This indicator light indicates fault trip
5	Reset button	Press	Use in fault state and restore the fault

7.2 The 60L1 display module button and LED indicator light are shown in Table 12:

Table 12

Serial No.	Name	State	Function Description
1	Start 1 button	Press	Manual mode, two-part mode, two-speed mode, star triangle operation start 1 relay
2	Start 2 button	Press	Operate and start the 2 relay in manual mode and two-speed mode
3	Stop button	Press	Release starting relay
4	Reset button	Press	Use in fault state and restore the fault
5	Cancel button	Press	Exit menu;Cancel the operation
6	Left keys	Press	Upside-down menu;Data is shifted when data is modified
7	Right key	Press	Scroll down menu;Modify the data
8	Confirm button	Press	Enter the Settings menu and write the modified data
13	Starting LED indicator light	bright	This indicator lamp is always on to indicate that the motor is in starting state
14	Running LED indicator light	bright	The indicator light is always on to indicate that the motor is in running state
15	Stop LED indicator light	bright	The indicator light is always on to indicate that the motor is in a stopped state
16	Alarm LED indicator light	bright	The light indicates an alarm
17	Trip LED indicator light	bright	This indicator light indicates fault trip

7.3 60L2 display module button and LED indicator light are shown in Table 13:

Table13

Serial Noo	Name	state	Function Description
1	Key 1	Press	Under different display interfaces, the button function of 60L2 display unit is not fixed. Users can operate according to the button function instructions in the left display screen.
2	Key 2	Press	
3	Key 3	Press	
4	Key 4	Press	
5	Key 5	Press	
13	Starting LED indicator light	bright	This indicator lamp is always on to indicate that the motor is in starting state
14	Running LED indicator light	bright	The indicator light is always on to indicate that the motor is in running state
15	Stop LED indicator light	bright	The indicator light is always on to indicate that the motor is in a stopped state
16	Alarm LED indicator light	bright	The light indicates an alarm
17	Trip LED indicator light	bright	This indicator light indicates fault trip

Note: When the backlight of 60L1 and 60L2 display unit becomes dark, press any button to light up the backlight.

7.4 60L1 display module introduction

7.4.1 Data display interface

After the protector is powered on, it enters the data display interface. Press "◀" and "▶" to scroll through the current, voltage, DI/DO state and other information. The specific display content is shown in Figure 16 (the figure below shows the display value in the stopped state)

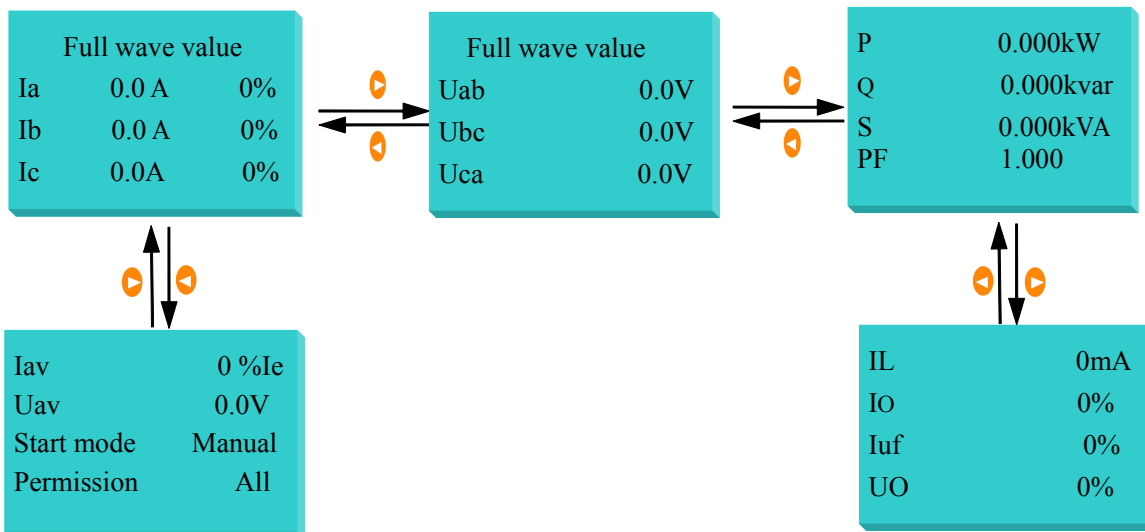

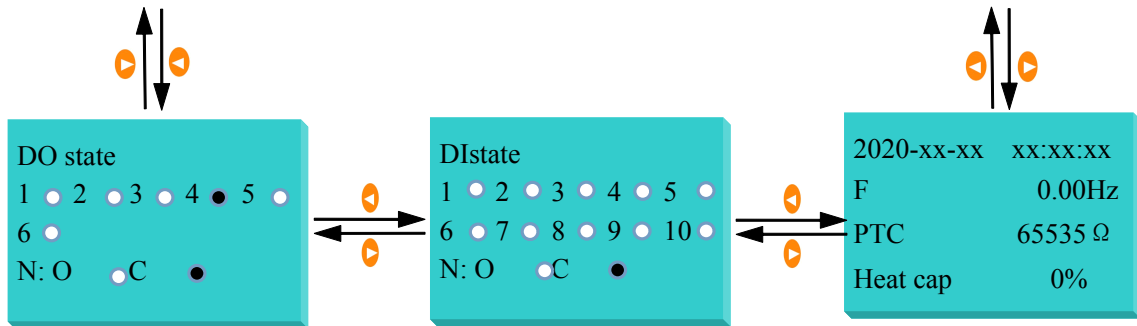

FIG.15 60L1 display unit data display interface

7.4.2 Parameter viewing and setting

When you need to view or set a parameter, first press "OK" to enter the password interface and enter the correct password (default 0001) before entering the main menu. Press the arrow key to move the cursor to the correspond to option, press the "OK" key to enter, and select the correspond to sub-menu for viewing or modification. Figure 17 shows an example of looking at Ethernet communication Settings:

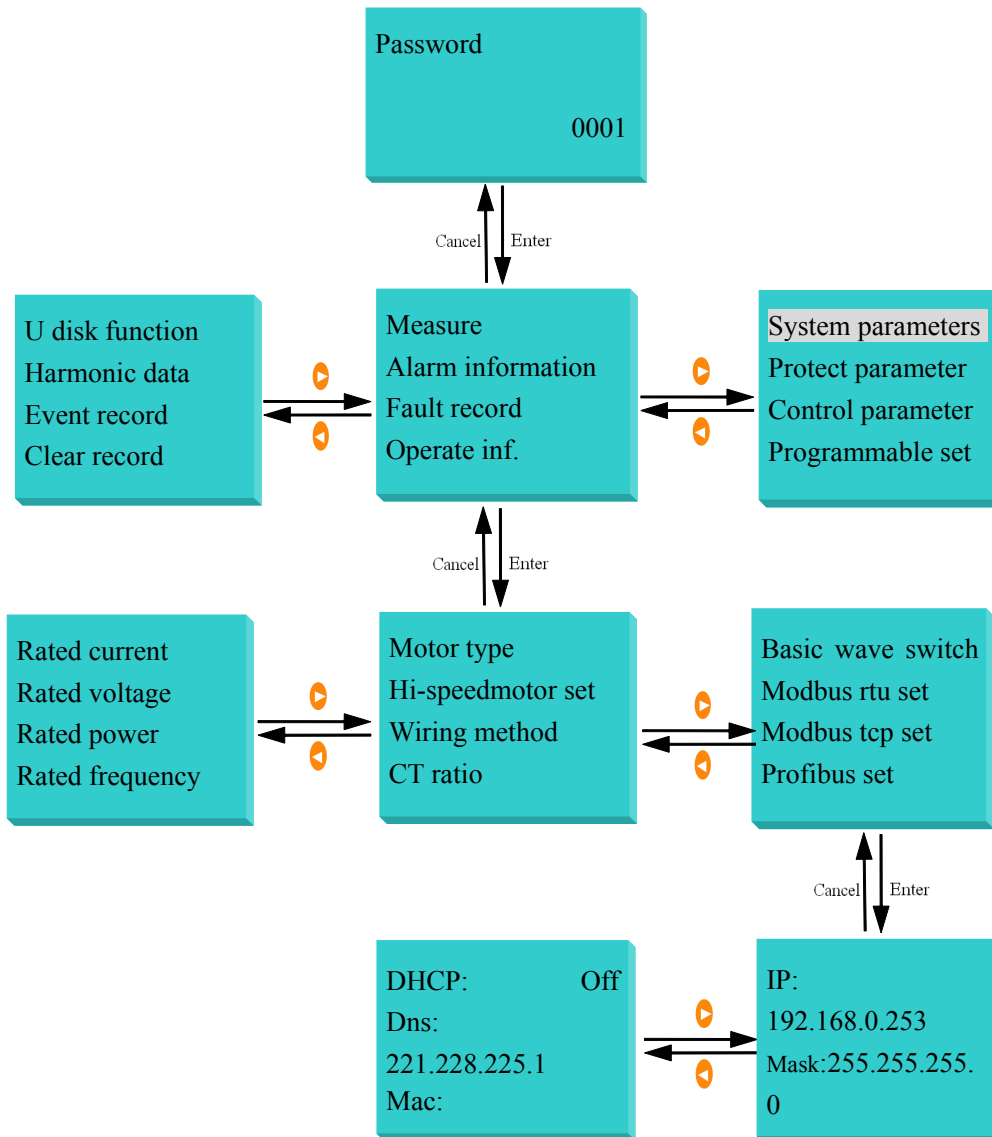

Fig.16 Shows the operation diagram of Ethernet communication parameters

7.5 60L2 Display unit Introduction

60L2 interface distribution is shown in Figure 18:

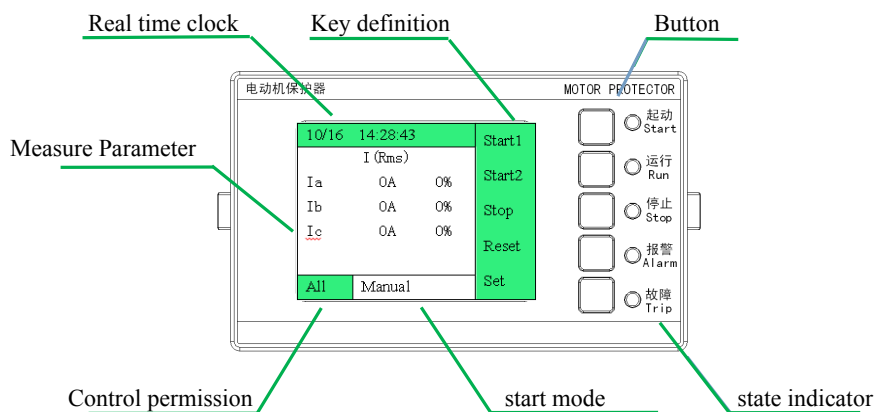

Fig. 17 60L2 display unit interface distribution

7.5.1 Data display interface

60L2 display unit data display interface automatically switches in the order shown in Figure 18:

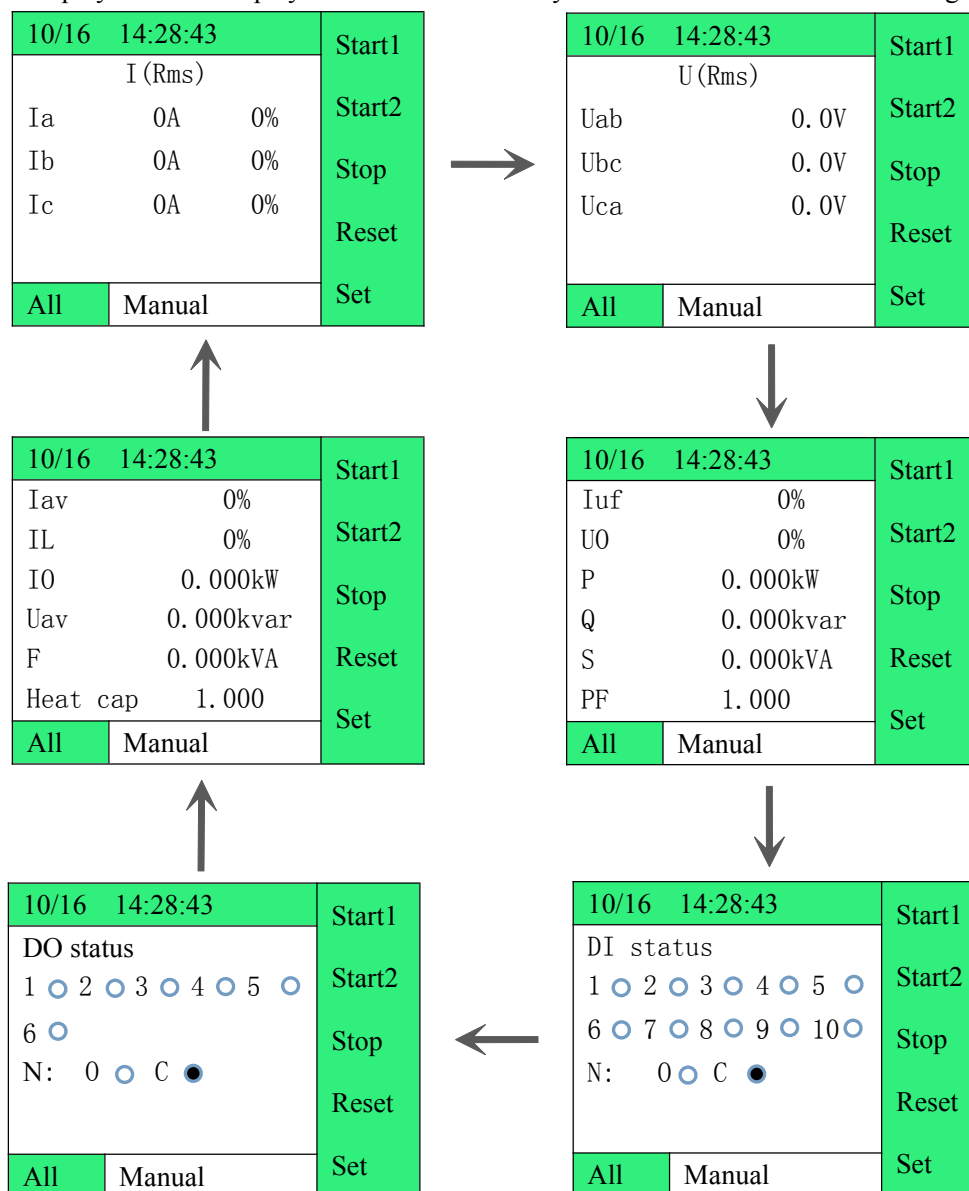

Fig.18 60L2 display unit data display interface

7.5.2 Parameter viewing and setting

When viewing or setting a parameter, first press "Set" to enter the password interface according to the instructions in the "Real-time Definition of Keys" bar. After entering the correct password (default 0001), press "OK" to enter the main menu. Press the arrow key to move the cursor to the correspond to option, press the "OK" key to enter, and select the correspond to sub-menu for viewing or modification. Each key has different functions with the menu switching, and users can operate according to the instruction of "Real-time definition of keys" on the left. Figure 19 takes a look at the harmonic data as an example:

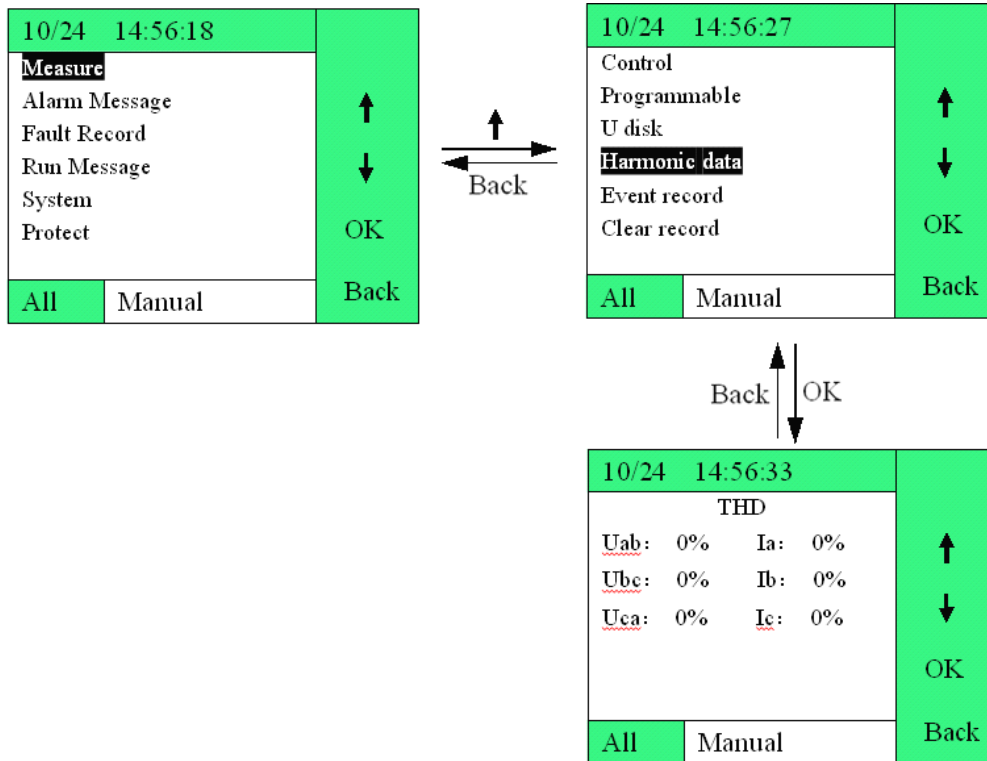

FIG. 19 60L2 display unit harmonic data view operation diagram

7.6 Menu description

See Table 14 for the ARD3M menu:

Table 14

Serial No.	Main menu	Function	Type	Setting Range	Default value	Unit
1	Measured parameter	Fundamental wave current	—	—	—	A
		Effective current	—	—	—	A
		Fundamental wave voltage	—	—	—	V
		RMS voltage	—	—	—	V
		Voltage phase Angle	—	—	—	
		Other electrical	—	—	—	

		parameters				
2	Alarm information	—	—	—	—	
3	Fault record	—	—	—	—	
4	Running information	Running time of this time	—	—	—	h
		Stop time of this time	—	—	—	h
		Total running time	—	—	—	h
		Total stop time	—	—	—	h
		Start qty	—	—	—	
		Trip qty	—	—	—	
		Maximum start current	—	—	—	A
		Maximum running current	—	—	—	A
5	System parameter	Rated current	—	0.1~5000	1	A
				0.1~5000	5	
				6.3~25	25	
				25-100	100	
				63~250	250	
				250~800	800	
		Rated voltage	—	57-1200V	380	V
		Rated power	—	0.12-999kW	—	
		Rated frequency	—	45-70	50	Hz
		Motor type	—	Common increased motor	Common motor, safety	
		High speed motor setting	Rated current	0.1~5000	1	
				0.1~5000	5	
				6.3~25	25	
				25-100	100	
63~250	250					
250~800	800					
	Rated power	0.12-999kW	—			
Connection mode	—	1P2L、3P3L、3P4L	3P4L			
CT ratio	—	1A spec.:1-5000 5A spec.:1-1000	1			

	Protection selection	—	Fundamental wave value, full wave value	Full wave value	
	Modbus RTU setting	ADD 1	1-247	1	
		Baud rate1	1200、2400、4800、9600、19200、38400	9600	bps
		Check digit 1	None/2stop/Odd/Even	None	
		ADD 2	1-247	2	
		Baud rate2	2400、4800、9600、19200、38400	9600	bps
		Check digit 2	None/2stop/Odd/Even	None	
	Modbus TCP setting	IP	—	192.168.0.253	
		Mask	—	255.255.255.0	
		Gate	—	192.168.0.1	
		Port	—	502	
		DHCP	—	off	
		Dns	—	221.228.225.1	
		Mac	—	4C-4B-F9-19-85-99	
	Profibus setting	Addr1	1-126	2	
		Addr2	1-126	3	
	Profinet setting	Name	—		
		Status	—	0x0000	
		Mac	—	00-00-00-00-00-00	
		IP	—	0.0.0.0	
	Switch function	Running record	on/off	off	
		Electric leakage protection	on/off	off	
		Fault wave record	on/off	off	
	Transmitting set	Type 1	Ia、Ib、Ic、Iav、Uab、Ubc、Uca、Uav、PTC、Heat capacity、P、F	Iav	
		Full value 1		2 times rated current	
		Type 2	Ia、Ib、Ic、Iav、Uab、Ubc、Uca、Uav、PTC、Heat capacity、P、F	Iav	
		Full value 2		2 times rated current	
	Language selection	—	Chinese, English	Chinese	

		backlight	——	1-30s, 0 is normally on	0	
		Liquid crystal contrast	——	0-100	50	%
		password	——	0001-9999	0001	
		Time Setting	——	——	——	
		Main interface index	——	0-8	——	
		Software version	——	——	——	
		Factory reset	——	Yes, no	——	
6	Protection paramete (low speed)	Fixed time overload	Alarm delay	0.1-600.0s	0.1s	s
			Trip delay	0.1-600.0s	5.0s	s
			Alarm threshold	100-800%	110%	%
			Trip threshold	100-800%	120%	%
			Action stage	Start: allowed/forbidden	Allow	
				Run: Allow/forbidden	Allow	
				Stop: Allowed/forbidden	forbidden	
			Return coefficient		5%	
		Alarm, trip allowed	Alarm:Allowed/forbid den	Allow		
			Trip:Allowed/forbidd en	Allow		
		Inverse time overload	Trip level	1、 2、 3、 5、 10、 15、 20、 25、 30、 35、 40	5	Class
			tE Trip level	2、 3、 4、 5、 6、 8、 10、 12、 15	2	Class
			Start setting	100~800%	120	%
			Reset method	Off/on	Off	
			Cooling time	0-30min	1min	min
			Alarm threshold	1-99%	80%	%
			Action stage	Start: allowed/forbidden	Allow	
Run: allowed/forbidden	Allow					
Stop:allowed/forbidde n	Forbidden					
Starting screen time	0-25.0s	0.5s	s			

			Alarm, trip allowed	Alarm:allowed/forbidden	Allow	
				Trip:allowed/forbidden	Allow	
		under load protection	Alarm delay	0.1-600.0s	1.0s	s
			Trip delay	0.1-600.0s	5.0s	s
			Alarm threshold	10-99%	70%	%
			Trip threshold	10-99%	50%	%
			Action stage	Start: allowed/forbidden	allow	
				Run: allowed/forbidden	Forbidden	
				Stop: Allowed/forbidden	Forbidden	
			Return coefficient		5%	
			Alarm, trip allowed	Alarm:allowed/forbidden	Allow	
				Trip:allowed/forbidden	Forbidden	
		phase loss protection	Alarm time delay	0.1-600.0s	0.1s	s
			Trip delay	0.1-600.0s	1.0s	s
			Action stage	Start: allowed/forbidden	Allow	
				Run: allowed/forbidden	Allow	
				Stop: Allowed/forbidden	Forbidden	
			Return coefficient		5%	
			Alarm, trip allowed	Alarm:allowed/forbidden	Allow	
				Trip:allowed/forbidden	Allow	
		Current imbalance	Tripping delay	0.1~600	1.0	S
			Alarm	on/off	on	
			Tripping	on/off	on	
			Alarm threshold	10~80%	20	%
			Alarm threshold	10~80%	30	%
			Tripping delay	0.1~600	5.0	S
			Action stage	Start:	Forbidden	

				allowed/forbidden		
				Run: allowed/forbidden	Allow	
				Stop: Allowed/forbidden	Forbidden	
			Alarm	on/off	On	
			Tripping	on/off	On	
		Block Protection	Alarm delay	0.1-600.0s	0.1s	s
			Tripping delay	0.1-600.0s	5.0s	s
			AlarmThreshold	100-700%	500%	%
			Trip Threshold	100-700%	600%	%
			Action stage	Start: allowed/forbidden	Allow	
				Run: allowed/forbidden	Forbidden	
				Stop: Allowed/forbidden	Forbidden	
			Return coefficient		5%	
			Alarm, trip allowed	Alarm:allowed/forbidden	Allow	
				Trip:allowed/forbidden	Allow	
		Ground fault protection	Alarm delay	0.1-600.0s	0.1s	s
			Tripping delay	0.1-600.0s	0.1s	s
			Alarm threshold	20-100%	20%	%
			Trip Threshold	20-100%	50%	%
			Action stage and tripping mode	Start: allowed/forbidden	Allow	
				Run: allowed/forbidden	Allow	
				Stop: Allowed/forbidden	Forbidden	
				Trip mode: circuit breaker/contactator	circuit breaker	
			Return coefficient		5%	
		Starting screen time	0.0-600s	0.0	s	
		Alarm, Tripping allowed	Alarm:allowed/forbidden	Allow		

				Trip:allowed/forbidden	Allow	
	Electric leakage protection	Alarm delay	0.1-600.0s	0.1s	s	
		Tripping delay	0.1-600.0s	0.5s	s	
		Alarm threshold	100-1000mA	200mA	mA	
		Trip Threshold	100-1000mA	300mA	mA	
		Action stage and tripping mode	Start: allowed/forbidden	Allow		
			Run: allowed/forbidden	Allow		
			Stop: allowed/forbidden	Forbidden		
			Trip mode: circuit breaker/contactors	circuit breaker		
		Return coefficient		5%		
		Starting screen time	0.0-600s	0.0	s	
		Alarm, Tripping allowed	Alarm:allowed/forbidden	Allow		
			Trip: allowed/forbidden	Allow		
		Short circuit protection	Alarm delay	0.1-25.0s	0.1s	s
	Tripping delay		0.1-25.0s	0.1s	s	
	Alarm threshold		100-800%	Start Alarm400%	%	
				Run Alarm400%		
	Trip Threshold		100-800%	Start trip 500%	%	
				Run trip 500%		
	Action stage		Start: allowed/forbidden	Allow		
			Run: allowed/forbidden	Allow		
			Stop: allowed/forbidden	Forbidden		
	Return coefficient			5%		
	Alarm, Tripping	Alarm:allowed/forbid	Allow			

			allowed	den		
				Trip: allowed/forbidden	Allow	
		Overflow protection	Protect threshold	100~700%	600	%
			Alarm, trip allowed	Alarm:allowed/forbid den	Allow	
				Trip: allowed/forbidden	Allow	
		Blocking protection	Alarm delay	0.1-600.0s	0.1s	s
			Tripping delay	0.1-600.0s	5.0s	s
			Alarm threshold	100-700%	150%	%
			Trip Threshold	100-700%	250%	%
			Action stage	Start: allowed/forbidden	Forbidden	
				Run: allowed/forbidden	Allow	
				Stop: allowed/forbidden	Forbidden	
			Return coefficient		5%	
		Alarm, trip allowed	Alarm:allowed/forbid den	Allow		
			Trip: allowed/forbidden	Allow		
		Start timeout	action threshold	100%-200%	110%	%
Timeout time	0.1-600s		10.0s	s		
Alarm, trip allowed	Alarm:allowed/forbid den		Allow			
	Trip: allowed/forbidden		Allow			
Start times	Timeout quantity	1-10	10	Time s		
	Time range	10-300min	30min	min		
	Alarm, trip allowed	Alarm:allowed/forbid den	Allow			
		Trip: allowed/forbidden	Allow			
overvoltage	Alarm delay	0.1-600.0s	0.1s	s		
	Tripping delay	0.1-600.0s	5.0s	s		
	Alarm threshold	110-150%	110%	%		

			Trip Threshold	110-150%	120%	%	
			Action stage	Start: allowed/forbidden	Allow		
				Run: allowed/forbidden	Allow		
				Stop: allowed/forbidden	Allow		
			Return coefficient		5%		
			Alarm, trip allowed	Alarm:allowed/forbid den	Allow		
				Stop: allowed/forbidden	Allow		
		Under voltage	Alarm delay	0.1-600.0s	0.1 s	s	
			Tripping delay	0.1-600.0s	5.0s	s	
			Alarm threshold	50-90%	90%	%	
			Trip Threshold	50-90%	80%	%	
			Action stage	Start: allowed/forbidden	Allow		
				Run: allowed/forbidden	Allow		
				Stop: allowed/forbidden	Allow		
				Return coefficient		5%	
			Alarm, trip allowed	Alarm:allowed/forbid den	Forbidden		
				Stop: allowed/forbidden	Forbidden		
		Voltage imbalance	Alarm delay	0.1-600.0s	0.1 s	s	
			Tripping delay	0.1-600.0s	0.5s	s	
			Alarm threshold	10-99%	15%	%	
			Trip Threshold	10-99%	20%	%	
			Action stage	Start: allowed/forbidden	Allow		
				Run: allowed/forbidden	Allow		
				Stop: allowed/forbidden	Allow		
				Return coefficient		5%	
			Alarm, trip allowed	Alarm:allowed/forbid den	Forbidden		

				Trip: allowed/forbidden	Forbidden	
		Phase sequence	Alarm delay	0.1-25.0s	0.1s	s
			Tripping delay	0.1-25.0s	1.0s	s
			Alarm threshold	0.5-5.0°	5.0°	°
			Trip Threshold	0.5-5.0°	9.9°	°
			Action stage	Start: allowed/forbidden	Allow	
				Run: allowed/forbidden	Allow	
				Stop: allowed/forbidden	Allow	
			Return coefficient		0.5°	
			Alarm, trip allowed	Alarm:allowed/forbid den	Forbidden	
				Trip: allowed/forbidden	Forbidden	
		over power	Alarm delay	0.1-600.0s	0.1s	s
			Tripping delay	0.1-600.0s	5.0s	s
			Alarm threshold	100-700%	150%	%
			Trip Threshold	100-700%	250%	%
			Action stage	Start: allowed/forbidden	Allow	
				Run: allowed/forbidden	Allow	
				Stop: allowed/forbidden	Forbidden	
			Return coefficient		5%	
			Alarm, trip allowed	Alarm:allowed/forbid den	Forbidden	
				Trip: allowed/forbidden	Forbidden	
		under-power	Alarm delay	0.1-600.0s	0.1s	s
			Tripping delay	0.1-600.0s	5.0s	s
			Alarm threshold	0-100%	80%	%
			Trip Threshold	0-100%	50%	%
			Action stage	Start: allowed/forbidden	Allow	
				Run: allowed/forbidden	Allow	

				Stop: allowed/forbidden	Forbidden	
			Return coefficient		5%	
			Alarm, trip allowed	Alarm:allowed/forbid den	Forbidden	
				Trip: allowed/forbidden	Forbidden	
	temperature pr otection		NTC/PTC	NTC/PTC	PTC	
			Alarm delay	0.1-600.0s	0.1s	s
			Tripping delay	0.1-600.0s	5.0s	s
			Alarm threshold	100-30000 Ω	1600 Ω	Ω
			Trip Threshold	100-30000 Ω	3600 Ω	Ω
			Action stage	Start: allowed/forbidden	Allow	
				Run: allowed/forbidden	Allow	
				Stop: allowed/forbidden	Forbidden	
			Reset method	Manual and automatic	automatic	
			Return resistance value	100-30000 Ω	1500 Ω	
			Alarm, trip allowed	Alarm:allowed/forbid den	Forbidden	
				Trip: allowed/forbidden	Forbidden	
		external fault		Alarm delay	0.1-600.0s	0.1s
			Tripping delay	0.1-600.0s	5.0s	s
			Action stage	Start: allowed/forbidden	Allow	
				Run: allowed/forbidden	Allow	
				Stop: allowed/forbidden	Forbidden	
			Alarm, trip allowed	Alarm:allowed/forbid den	Forbidden	
		Trip: allowed/forbidden		Forbidden		
	Insulation fault		Alarm time delay	0.1-600.0s	0.1s	s
			Tripping delay	0.1-600.0s	5.0s	s
			Action stage	Start: allowed/forbidden	Forbidden	

				Run: allowed/forbidden	Forbidden		
				Stop: allowed/forbidden	Allow		
				Alarm, trip allowed	Alarm:allowed/forbid den	Forbidden	
					Trip: allowed/forbidden	Forbidden	
			Run timeout	Alarm threshold		10000h	h
				Action stage	Start: allowed/forbidden	Allow	
					allowed/forbidde	Allow	
					Stop: allowed/forbidden	Forbidden	
		Alarm allowed	allowed/forbidden	Forbidden			
		Failure frequency	Alarm threshold		1000 times	times	
			Action stage	Start: allowed/forbidden	Allow		
				Run: allowed/forbidden	Allow		
				Stop: allowed/forbidden	Allow		
			Alarm allowed	allowed/forbidden	Forbidden		
Overpower protection	Alarm threshold	100~700%	150	%			
	Trip Threshold	100~700%	250	%			
	Tripping delay	0.1-600	5.0	S			
	Alarm	on/off	Off				
	Tripping	on/off	Off				
	Underpower protection	Alarm threshold	0~100%	80	%		
		Trip Threshold	0~100%	50	%		
		Tripping delay	0.1-600	5.0	S		
		Alarm	on/off	Off			
		Tripping	on/off	Off			
Temperature protection	PTC type	on/off	On				
	Return resistance value	0 (Shut down) 、 100-30000	0	Ω			
	Alarm resistance value	100~30000	1600	Ω			
	Tripping resistance value	100~30000	3600	Ω			
	Tripping delay	0.1~600	5.0	S			

		External fault	Alarm	on/off	On		
			Tripping	on/off	On		
			Tripping delay	0.1~600	5.0	S	
			Alarm	on/off	Off		
			Tripping	on/off	Off		
		Protect the parameters (high speed)	Refer to the low speed protection setting sheet				
7	Control parameter	Control access	Control access	Display unit, in - place, communication, remote, three choice one, two choice one, all control	All control		
		Start method	Start mode	Protection mode, manual mode, two-step mode, two-speed mode, Y- Δ start, auto-step-down	Protected mode		
			start1delay	0.1-600	3.0	S	
		Self start	Self start mode	recover/start	start		
			Self start delay	0.1~600	5.0	S	
			Self start control	on/off	Off		
		Voltage loss restart	Recovery voltage	70-95%	80	%	
			Voltage drop	50-90%	50	%	
			Voltage shock time	0.5-300.0	5.0	S	
			Restart delay	1.0-60.0s	30.0	S	
			Immediate restart time	0.1-10.0s	0.5	S	
			Restart function	on/off	Off		
			DI setting	DI1 type	Normally on/normally off	Normally on	

8	Programmable Setting		DI1	Ordinary DI, starting 1 (in situ), 1 (remote) starting, starting 2 (in situ), 2 (remote), parking (in situ), parking (remote), reset, emergency stop, external fault, single point 1 (in situ) start-stop, single point 1 (remote) start-stop, single point 2 (in situ) start-stop, single point 2 (remote) start-stop, single point 1 can make start-stop, single point 2 can make start-stop, control over 1, control over 2	start1	
			DI2	Ditto	Start2	
			DI3	Ditto	Stop	
			DI4	Ditto	Reset	
			DI5	Ditto	Urgent Stop	
			DI6	Ditto	External fault	
			DI7	Ditto	control right1	
			DI8	Ditto	control right 2	
			DI9	Ditto	Ordinary DI	
			DI10	Ditto	Ordinary DI	
			DO1 type	Normally on/normally off	Normally on	
			DO1 Definition	No input, starting 1, 2, 3, parking, starting jumped contactor, circuit		

		DO setting		breakers, fault Alarm output, tripping fault output, the output state stopped, the starting state output, the output operation state, the communication control output, the output device self-checking, the device output power, nowhere electric process output chain, electric reset signal output, protected mode have nowhere electricity output 1, protected mode electricity output 2, logic diagram output 1 output logic diagram, logic diagram output 2, 3, 22-31 correspond to DI1-10 control the DO output	start1		
				Pulse time	0.3-25.0s	0.0s	s
				DO2	Ditto	start2	
				DO3	Ditto	trip	
				DO4	Ditto	trip	
				DO5	Ditto	Breaker trip	
				DO6	Ditto	Alarm	
		Logic diagram setting	input A	Input A definition	Close;DI1-10;DO1 - DO6;Starting 1;Starting 2;Starting 3;Stop;Emergency shutdown;Stop state;Starting state;Running state;Alarm	DI1	

					status; Trip status; Trip type (choose one of 22 fault types); Alarm types (choose one of 24 Alarm types))		
				Input A logic	Positive logic/Reserve logic	Positive logic	
				Input A delay	0.0-60.0s	0.0s	
			input B	Input B definition	Ditto	Off	
				Input B logic	Positive logic/Reserve logic	Positive logic	
				Input B delay	0.0-60.0s	0.0s	
			input C	Input C definition	Ditto	Off	
				Input C logic	Positive logic/Reserve logic	Positive logic	
				Input C delay	0.0-60.0s	0.0s	
			input D	Input D definition	Ditto	Off	
				Input D logic	Positive logic/Reserve logic	Positive logic	
				Input D delay	0.0-60.0s	0.0s	
			input E	Input E definition	Ditto	Off	
				Input E logic	Positive logic/Reserve logic	Positive logic	
				Input E delay	0.0-60.0s	0.0s	
				Logic diagram1	Off, A, A*B, A+B, A*B*C, (A+B)*C, (A*B)+C, A+B+C, A*B*C*D, (A+B)*C*D, (A*B+C)*D, (A+B+C)*D, A*B*C+D, (A+B)*C+D, A*B+C+D,	A	

				$A+B+C+D$ 、 $A*B*C*D*E$ 、 $(A+B)*C*D*E$ 、 $(A*B+C)*D*E$ 、 $(A+B+C)*D*E$ 、 $(A*B*C+D)*E$ 、 $((A+B)*C+D)*E$ 、 $(A*B+C+D)*E$ 、 $(A+B+C+D)*E$ 、 $A*B*C*D+E$ 、 $(A+B)*C*D+E$ 、 $(A*B+C)*D+E$ 、 $(A+B+C)*D+E$ 、 $A*B*C+D+E$ 、 $(A+B)*C+D+E$ 、 $A*B+C+D+E$ 、 $A+B+C+D+E$		
			Logic diagram 2	Ditto	A	
			Logic diagram 3	Ditto	A	
		Test	DO1	Off/on	Off	
			DO2	Off/on	Off	
			DO3	Off/on	Off	
			DO4	Off/on	Off	
			DO5	Off/on	Off	
			DO6	Off/on	Off	
9	U disk function	program update	upgrade the subject	Yes/no	no	
			upgrade the LCD	Yes/no	no	
		Record export	Derived fault waveform			
			Export event record			
			Export run record			
10	Harmonic data					
11	Event log	DI Displacement records				
		Start recording				

		Restart record				
		Restart record				
12	Clear record	Clear record password		0000-9999	0001	

8.Communication Settings and instructions

8.1 Modbus RTUCommunication Protocol Overview

Electrical interface: RS485 half duplex

Baud: 1200/2400/4800/9600/19200/38400

Address: Consists of one byte (8-bit binary), 0 to 255 in decimal, only 1 to 247 in the system, the rest Reserved

Error detection:CRC

Data format:	Address code	Function code	Data area	CRC check
--------------	--------------	---------------	-----------	-----------

Data length:	1 byte	1 byte	N byte	2 byte
--------------	--------	--------	--------	--------

Each byte bit: 1 bit start, 8 bit data (least significant bit sent first), no parity, 1 bit stop

MODBUS function code supported by ARD3M:

01 (0x01) Function code: Read coil state (relay output DO, address 0 correspond tos to DO1)

02 (0x02) Function code: Read switch input state (DI, address 0 correspond tos to DI1)

03/04 (0x03, 0x04) Function code: read hold register

05 (0x05) Function code: write coil state (control relay output DO, address 0 correspond tos to DO1)

06 (0x06) Function code: Write a single register

16 (0x10) function code: Write multiple registers

Note: The operation control bit and output control bit are written in 16 function codes.

Communications applications

The examples in this section use the following tabular format (in hexadecimal data) whenever possible

Addr	Fun	Data start		Data		CRC16	
		reg Hi	reg Lo	reg Hi	reg Lo	Lo	Hi
01H	03H	00H	00H	00H	06H	C5H	C8H
Add	Function code	Data starting address		Data read qty		Cyclic redundancy check code	

Read the data

Example 1: Read register using the 01 function: read the OUTPUT status of DO1-DO5 relay of the 01 ARD3M protector

Check data frame	01 02 00 00 00 05 B8 09
------------------	-------------------------

Return data frame	01 02 01 10 A0 44
-------------------	-------------------

Example 2: Register read using the 02 function: read the di1-DI5 switch input status of the 01 ARD3M protector

Check data frame	01 01 00 00 00 05 FC 09
Return data frame	01 01 01 0C 51 8D

Example 3: Register read using the 03 or 04 function: read 01 ARD3M and read 3 data from address 00

Check data frame	01 03 00 00 00 03 11 5D
Return data frame	01 03 06 00 00 00 00 00 0E D1

Write the data

Example 4: Use the 05 function to write registers

Close DO1 relay no. 01 ARD3M:

Check data frame	01 05 00 00 FF 00 8C 3A
Return data frame	01 05 00 00 FF 00 8C 3A

Disconnect DO1 relay of No. 01 ARD3M:

Check data frame	01 05 00 00 00 00 CD CA
Return data frame	01 05 00 00 00 00 CD CA

Example 5: Write register using 06 function: output DO2 of 01 ARD3M. The indicating register address of switch input/output state is 0013H, bit 0-9 correspond to Di1-10, bit 10 correspond to DO6, and bit 11-15 correspond to DO1-5.

Check data frame	01 06 00 13 10 00 75 CF
Return data frame	01 06 00 13 10 00 75 CF

Example 6: Write register with 16 function: output DO2 of 01 ARD3M. The indicating register address of switch input/output state is 0013H, bit 0-9 correspond to Di1-10, bit 10 correspond to DO6, and bit 11-15 correspond to DO1-5.

Check data frame	01 10 00 13 00 01 02 10 00 A9 33
Return data frame	01 10 00 13 00 01 F0 0C

Description:

03: function code

06: Hexadecimal, decimal number 6, means 6 bytes of data

OE D1: Cyclic redundancy check code

The detailed MODBUS address of ARD3M is shown in table 15 and 16 : (table 15 is the original ARD3 address, which is used for compatibility with the original ARD3 product)

Table 15

Classification	Add	Add	Parameter	Read write attribute	Value range	Type
Add	0	0x00	L1 Phase current (full wave/fundamental wave)	R	0-65535 When the fundamental switch is on, the fundamental value/current scaling factor is the actual value	word
				R		word
	1	0x01	L2 Phase current (full wave/fundamental wave)	R		word
				R		
	2	0x02	L3 Phase current (full wave/fundamental wave)	R		word
				R		
	3	0x03	Leakage current	R	0-3000mA	word
			Ground current percent	R	0-100%	
	4	0x04	Uab Line voltage (full wave/fundamental wave)	R	0~1999.9	word
	5	0x05	Ubc Line voltage (full wave/fundamental wave)	R	0~1999.9	word
	6	0x06	Uca Line voltage (full wave/fundamental wave)	R	0~1999.9	word
	7	0x07	Apparent power (full wave/fundamental wave)	R	32 bit signed number, High characters before, low characters after	High byte
	8	0x08		R		Low byte
	9	0x09	Active power (full wave/fundamental wave)	R	The fundamental value is when the fundamental switch is turned on	High byte
	10	0x0A		R		Low byte
11	0x0B	Active electric energy (full wave/fundamental wave)	R	32 bit unsigned number, High characters before, low characters after The fundamental value is when the fundamental switch is turned on	High byte	
12	0x0C		R		Low byte	
13	0x0D	Power factor (full wave/fundamental wave)	R	-1.000-1.000 Unit:0.001	word	
14	0x0E	Current imbalance Degree	R	0-100%	word	

15	0x0F	Cumulative heat capacity Percentage	R	0-100%	word
16	0x10	Temperature value	R	0-65535 Ω	word
17	0x11	Motor this run time	R	0-65535 hour	word
18	0x12	Motor this stop time	R	0-65535 hour	word
19	0x13	Switching input/output	R/W	Bit0-bit9 correspond to switch input DI1-DI10, Bit10 correspond to DO6, and BIT11-15 correspond to DO1-DO5	word
20	0x14	Trip fault indication 1	R	Bit0 reverse time overload trip Bit1 ground trip Bit2 under load trip Bit3 phase break trip Bit4 under voltage trip Bit5 over voltage trip Bit6 blocking trip Bit7 blocking trip Bit8 unbalanced trip Bit9 PTC temperature trip Bit10 external fault trip Bit11 start timeout trip Bit12 overpower trip Bit13 underpower trip Bit14 phase sequence trip Bit15 short circuit trip	word
21	0x15	Trip fault indication 2	R	Bit0 constant time overload trip Bit1 voltage imbalance trip Bit2 overflow trip Bit3 insulation monitoring trip Bit4 start times trip Bit5 running time trip Bit6 failure times trip Bit7 leakage current trip	word
			R	Bit0 reverse time overload alarm Bit1 ground alarm Bit2 under load alarm Bit3 phase break alarm Bit4 undervoltage alarm	word

	22	0x16	Fault alarm indication 1		Bit5 over voltage alarm Bit6 block turn alarm Bit7 blocking alarm Bit8 current imbalance alarm Bit9PTC temperature alarm Bit10 external fault alarm Bit11 start timeout alarm Bit12 overpower alarm Bit13 low power alarm Bit14 phase sequence alarm Bit15 short circuit alarm (0-no alarm,1-alarm)	
	23	0x17	Fault alarm indication 2	R	Bit0 fixed time overload alarm Bit1 voltage imbalance alarm Bit2 overflow alarm Bit3 insulation monitoring alarm Bit4 start times alarm Bit5 running time alarm Bit6 failure times alarm Bit7 leakage current alarm (0-no alarm,1-alarm)	word
	24	0x18	Current specification	R	0-1.6、1-6.3、2-25、3-100、 4-250、5-800、6-1、7-5	word
			Current scaling factor	R	1、10、100	
	25	0x19	A Phase overload percentage	R	0-999%	word
	26	0x1A	B Phase overload percentage	R	0-999%	word
	27	0x1B	C Phase overload percentage	R	0-999%	word
	28	0x1C	Overload percentage	R	0-999%	word
	29	0x1D	Frequency	R	15.00-75.00	word
	30	0x1E	Motor State	R	Motor thermal overload cooling remaining time	word
				R	Bit0 ready;Bit1 stop Bit2 start; Bit3 run;Bit4 alarm;Bit5 tripping	
	31-40	0x1F-0x28	Reserve	R		word

41	0x29	Operation control bit	R/W	1-stop, 2-start 1, 3-start 2	word
42	0x2A	Reserve	R		word
43	0x2B	Factory data reset	R/W	0xFFFF	word
44	0x2C	Total running time	R/W	0-65535 Hour	word
45	0x2D	Total stop time	R/W	0-65535 Hour	word
46	0x2E	Total number of starts	R/W	0-65535	word
47	0x2F	Total tripping times	R/W	0-65535	word
48	0x30	Year	R/W	2020-2099	word
49	0x31	Month	R/W	1-12	word
50	0x32	Day	R/W	1-31	
51	0x33	Hour	R/W	0-23	word
52	0x34	Min	R/W	0-59	word
53	0x35	Second	R/W	0-59	word
54	0x36	Reserve	R		word
55~94	0x37-0x5E	Variable feed type setting	R	0-Ia、1-Ib、2-Ic、3-Iav、4-Uab、5-Ubc、6-Uca、7-Uav、8-PTC、9-Heat capacity、10-P、11-F	word
95	0x5F	Mark the input of the residual current transformer	R/W	0 no input 1 input	word
96	0x60	Fundamental wave switch	R/W	1 base wave;0 RMS	word
97	0x61	Motor type	R/W	0 Ordinary motor;1 Increased safety motor	word
98	0x62	CT ratio	R/W	1A:1-5000 5A:1-1000 Other specifications are not available	word
99	0x63	Rated frequency	R/W	45-70	word
100	0x64	Motor rated current	R/W	1A:0.1-5000.0A 5A:0.5-5000.0A 1.6A:0.4-1.6A 6.3A:1.6-6.3A 25A:6.3-25.0A 100A:25.0-100.0A 250A:63.0-250.0A 800A:250.0-800.0A	word
101	0x65	Motor rated voltage	R/W	57-1200V	word
102	0x66	Motor rated power	R/W	High bit (Unit:W)	word
103	0x67		R/W	Low bit (Unit:W)	word
104	0x68	Starting time setting	R/W	0.1-600.0	word

	105	0x69	Wiring mode	R	Single phase mode 1 three phase four wire 2 three phase three wire	word
	106-1999	0x6A-07CF	Reserve	R		word

Table 16

Classification	Add	Add	Parameter	Read write attribute	Value range	Type
Real-time parameter	2000	07D0	A Phase effective value current percentage	R	0-1200%	word
	2001	07D1	B Phase effective value current percentage	R		word
	2002	07D2	C Phase effective value current percentage	R		word
	2003	07D3	Average effective value current percentage	R		word
	2004	07D4	Maximum RMS current Percentage	R		word
	2005	07D5	A Phase fundamental current percentage	R		word
	2006	07D6	B Phase fundamental current percentage	R		word
	2007	07D7	C Phase fundamental current percentage	R		word
	2008	07D8	Average fundamental current percentage	R		word
	2009	07D9	Maximum fundamental current percentage	R		word
	2010	07DA	Ground current percent	R		word
	2011	07DB	Positive sequence current percentage	R		word
	2012	07DC	Negative sequence current percentage	R	word	
	2013	07DD	A Phase fundamental current	R	0-65535/Current scaling factor is the actual value	word
	2014	07DE	B Phase fundamental current	R		word
	2015	07DF	C Phase fundamental current	R		word
2016	07E0	Uab Fundamental line voltage	R	0~1999.9V	word	

2017	07E1	Ubc Fundamental line voltage	R	0~1999.9V	word
2018	07E2	Uca Fundamental line voltage	R	0~1999.9V	
2019	07E3	Leakage current	R	30-3000mA	
2020	07E4	A Phase effective current	R	0-65535/current scaling factor is the actual value	word
2021	07E5	B Phase effective current	R		word
2022	07E6	C Phase effective current	R		word
2023	07E7	Uab RMS line voltage	R	0~1999.9V	word
2024	07E8	Ubc RMS line voltage	R	0~1999.9V	word
2025	07E9	Uca RMS line voltage	R	0~1999.9V	word
2026	07EA	Frequency	R	15.00-75.00Hz	word
2027	07EB	Degree of current imbalance	R	0-100%	
2028	07EC	Percentage of cumulative heat capacity	R	0-100%	word
2029	07ED	Temperature resistance	R	0-65535 Ω	word
2030	07EE	Zero sequence voltage percent	R	0-999%	High byte word
2031	07EF	Percentage of positive sequence voltage	R	0-999%	Low byte word
2032	07F0	Negative sequence voltage percentage	R	0-999%	signed short int
2033	07F1	Voltage imbalance	R	0-999%	
2034	07F2	AB Phase voltage phase Angle difference	R	0-359.9°	word
2035	07F3	BC Phase voltage phase Angle difference	R	0-359.9°	
2036	07F4	CA Phase voltage phase Angle difference	R	0-359.9°	
2037-2040	07F5-07F8	Reserved	R		
2041	07F9	Product internal temperature	R	-40.0~85.0, Unit:0.1 degree	
2042	07FA	Insulation monitoring	R	0-Normal 1-abnormal insulation	
2043	07FB	Reserved	R		

2044	07FC	Fundamental wave Total active power	R	32 bit signed number, High byte before, low byte after Unit:W	high byte word
2045	07FD		R		Low byte word
2046	07FE	Fundamental wave Total reactive power	R	32 bit signed number, High byte before, low byte after Unit:var	high byte word
2047	07FF		R		Low byte word
2048	0800	Fundamental wave Total apparent power	R	32 bit unsigned number, High byte before, low byte after Unit:VA	high byte word
2049	0801		R		Low byte word
2050	0802	Fundamental wave total active energy	R	32 bit unsigned number, High byte before, low byte after Unit:Wh	high byte word
2051	0803		R		Low byte word
2052	0804	Fundamental wave total reactive energy	R	32 bit unsigned number, High byte before, low byte after Unit:varh	high byte word
2053	0805		R		Low byte word
2054	0806	Fundamental wave A phase active	R	32 bit signed number, High byte before, low byte after Unit:W	high byte word
2055	0807		R		Low byte word
2056	0808	Fundamental wave B phase active	R	32 bit signed number, High byte before, low byte after Unit:W	high byte word
2057	0809		R		Low byte word
2058	080A	Fundamental wave C phase active	R	32 bit signed number, High byte before, low byte	high byte

				after Unit:W	word
2059	080B		R		Low byte word
2060	080C	Fundamental wave A phase reactive	R	32 bit signed number, High byte before, low byte after Unit:var	high byte word
2061	080D		R		Low byte word
2062	080E	Fundamental wave B phase reactive	R	32 bit signed number, High byte before, low byte after Unit:var	high byte word
2063	080F		R		Low byte word
2064	0810	Fundamental wave C phase reactive	R	32 bit signed number, High byte before, low byte after Unit:var	high byte word
2065	0811		R		Low byte word
2066	0812	Fundamental wave A phase apparent	R	32 bit unsigned number, High byte before, low byte after Unit:VA	high byte word
2067	0813		R		Low byte word
2068	0814	Fundamental wave B phase apparent	R	32 bit unsigned number, High byte before, low byte after Unit:VA	high byte word
2069	0815		R		Low byte word
2070	0816	Fundamental wave C phase apparent	R	32 bit unsigned number, High byte before, low byte after Unit:VA	high byte word
2071	0817		R		Low byte word
2072	0818	Total fundamental wave active power	R	32 bit signed number, High byte before, low byte after Unit:W	high byte word
2073	0819		R		Low

						byte word
2074	081A	Total fundamental wave reactive power	R	32 bit signed number, High byte before, low byte after Unit:var	high byte word	
2075	081B		R		Low byte word	
2076	081C	Total fundamental wave apparent power	R	32 bit signed number, High byte before, low byte after Unit:VA	high byte word	
2077	081D		R		Low byte word	
2078	081E	Fundamental wave total active energy	R	32 bit unsigned number, High byte before, low byte after Unit:Wh	high byte word	
2079	081F		R		Low byte word	
2080	0820	Fundamental wave total reactive energy	R	32 bit unsigned number, High byte before, low byte after Unit:varh	high byte word	
2081	0821		R		Low byte word	
2082	0822	Full wave A phase active	R	32 bit unsigned number, High byte before, low byte after Unit:W	high byte word	
2083	0823		R		Low byte word	
2084	0824	Full wave B phase active	R	32 bit unsigned number, High byte before, low byte after Unit:W	high byte word	
2085	0825		R		Low byte word	
2086	0826	Full wave C phase active	R	32 bit unsigned number, High byte before, low byte after Unit:W	high byte word	
2087	0827		R		Low byte word	

2088	0828	Full wave A phase reactive power	R	32 bit unsigned number, High byte before, low byte after Unit:var	high byte word
2089	0829		R		Low byte word
2090	082A	Full wave B phase reactive power	R	32 bit unsigned number, High byte before, low byte after Unit:var	high byte word
2091	082B		R		Low byte word
2092	082C	Full wave C phase Reactive	R	32 bit unsigned number, High byte before, low byte after Unit:var	high byte word
2093	082D		R		Low byte word
2094	082E	Full wave A phase apparent	R	32 bit unsigned number, High byte before, low byte after Unit:VA	high byte word
2095	082F		R		Low byte word
2096	0830	Full wave B phase apparent	R	32 bit unsigned number, High byte before, low byte after Unit:VA	high byte word
2097	0831		R		Low byte word
2098	0832	Full wave C phase apparent	R	32 bit unsigned number, High byte before, low byte after Unit:VA	high byte word
2099	0833		R		Low byte word
2100	0834	Fundamental wave power factor		-1.000~1.000	word
2101	0835	Fundamental wave A phase power factor		-1.000~1.000	word
2102	0836	Fundamental wave B phase power factor		-1.000~1.000	word
2103	0837	Fundamental wave C phase power factor		-1.000~1.000	word

2104	0838	Full wave power factor		-1.000~1.000	word
2105	0839	Full wave A phase power factor		-1.000~1.000	word
2106	083A	Full wave B phase power factor		-1.000~1.000	word
2107	083B	Full wave C phase power factor		-1.000~1.000	word
2108	083C	Year month	R/W	High byte:00-99,low byte:0-12	word
2109	083D	Day hour	R/W	High byte:0-31,low byte:0-23	word
2110	083E	Minute second	R/W	High byte:0-59,low byte:0-59	word
2111	083F	基波有功电能进位	R	0-65535	word
2112	0840	基波无功电能进位	R	0-65535	word
2113	0841	总有功电能进位	R	0-65535	word
2114	0842	总无功电能进位	R	0-65535	word
2115-2125	0843	Reserve	R		
2126	0844	Analog output 1	R	4.00-23.20 mA	word
2127	0845	Analog output 2	R	4.00-23.20 mA	word
2128-2299	0846-08FB	Reserve	R		
6000	1770	A phase voltage total harmonic content	R	0-100%	word
6001	1771	B phase voltage total harmonic content	R	0-100%	word
6002	1772	C phase voltage total harmonic content	R	0-100%	word
6003	1773	A phase current total harmonic content	R	0-100%	word
6004	1774	B phase current total harmonic content	R	0-100%	word
6005	1775	C phase current total harmonic content	R	0-100%	word
6006-6067	1776-17B3	A phase 2-63th voltage harmonic content	R	0-100%	word
6068-6129	17B4-17F1	B phase 2-63th voltage harmonic content	R	0-100%	word
6130-6191	17F2-182F	C phase 2-63th voltage harmonic content	R	0-100%	word
6192-6253	1830-186D	A phase 2-63th current harmonic content	R	0-100%	word

	6254-6 315	186F-1 8AB	B phase 2-63th current harmonic content	R	0-100%	word
	6316-6 377	18AC- 18E9	C phase 2-63th current harmonic content	R	0-100%	word
Run messag e	2300	08FC	Running time this time	R	0-65535hour	word
	2301	08FD	Stopping time this time	R	0-65535hour	word
	2302	08FE	Total run time	R	0-65535hour	word
	2303	08FF	Total stop time	R	0-65535hour	word
	2304	0900	Total start times	R	0-65535	word
	2305	0901	Total trip times	R	0-65535	word
	2306	0902	DI status	R	Bit0-bit9 correspond to switch input DI1-DI10	word
	2307	0903	DO status	R/W	Bit0 relay 1、 Bit1 relay 2、 Bit2 relay 3、 Bit3 relay 4、 Bit4 relay 5、 Bit5 relay 6	
	2308	0904	DI/DO type	R	bit0-bit5 correspond to to the relay mode in turn, 1 means normally closed bit13-bit12 means switch input type 11=DC24V,01=DC220V, 10=DC110V,00=AC220V	
	2309	0905	Motor status	R	bit0 Ready; bit1 Stop; bit2 Start; bit3 Run; bit4Alarm; bit5 Trip; bit7 0-low speed;1-high speed	word
2310	0906	Trip Breakdown fault indication 1		Bit0 reverse time overload trip Bit1 ground trip Bit2 under load trip Bit3 phase break trip Bit4 under voltage trip Bit5 over voltage trip Bit6 blocking trip Bit7 blocking trip Bit8 unbalanced trip Bit9 PTC temperature trip Bit10 external fault trip Bit11 start timeout trip Bit12 overpower trip Bit13 underpower trip Bit14 phase sequence trip Bit15 short circuit trip	word	

					(0-no tripping, 1-tripping)	
2311	0907	Trip Breakdown fault indication 2	R	Bit0 constant time overload trip Bit1 voltage imbalance trip Bit2 overflow trip Bit3 insulation monitoring trip Bit4 start times trip Bit5 running time trip Bit6 failure times trip Bit7 leakage current trip (0-no tripping, 1-tripping)	word	
2312	0908	Alarm fault indication 1	R	Bit0 reverse time overload alarm Bit1 ground alarm Bit2 under load alarm Bit3 phase break alarm Bit4 undervoltage alarm Bit5 over voltage alarm Bit6 block turn alarm Bit7 blocking alarm Bit8 current imbalance alarm Bit9PTC temperature alarm Bit10 external fault alarm Bit11 start timeout alarm Bit12 overpower alarm Bit13 low power alarm Bit14 phase sequence alarm Bit15 short circuit alarm (0-no alarm, 1-alarm)	word	
2313	0909	Alarm fault indication 2	R	Bit0 fixed time overload alarm Bit1 voltage imbalance alarm Bit2 overflow alarm Bit3 insulation monitoring alarm Bit4 start times alarm Bit5 running time alarm Bit6 failure times alarm Bit7 leakage current alarm (0-no alarm, 1-alarm)	word	
2314	090A	Overload remaining	R	0-30min	word	

		cooling time			
2315	090B	Maximum starting current by now	R	0-65535	word
2316	090C	Maximum Historical starting current	R	0-65535	word
2317	090D	Maximum current in operation by now	R	0-65535	word
2318	090E	Maximum Historical operation current	R	0-65535	word
2319	090F	Latest Fault Record Communication Address	R	4000、4050、4100、4150、4200、4250、4300、4350	word
2320	0910	Latest DI Change Record Communication Address	R	3000、3008、3016、3024、3032、3040、3048、3056	word
2321	0911	Latest Starting Record Communication Address	R	3200、3208、3216、3224、3232、3240、3248、3256	word
2322	0912	Latest Stopping Record Communication Address	R	3400、3408、3416、3424、3432、3440、3448、3456	word
2323	0913	Latest Restart Record Communication Address	R	3600、3608、3616、3624、3632、3640、3648、3656	word
2324	0914	下次故障录波条目位置	R	0-49	word
2325	0915	最新参数设置通讯地址	R	3800、3806、3812、3818、3824、3830、3836、3842	word
2326	0916	Running record start time-year month	R	High byte:00-99,low byte:0-12	word
2327	0917	Running record start time-day hour	R	High byte:0-31,low byte:0-23	word
2328	0918	Running record start time-minute second	R	High byte:0-59,low byte:0-59	word
2329	0919	Which minute is recoding currently	R	0-300	word
2330	091A	The time to wait for the next startup	R	10-300	word
2331	091B	The address of the latest power-on record	R	3920、3924、3928、3932、3936、3940、3944、3948	word
2332	091C	The address of the latest power-off record	R	3952、3956、3960、3964、3968、3972、3976、3980	word
2333	091D	The number of	R	0-60000	word

			power-on currently recorded			
	2334	091E	The number of power-off currently recorded	R	0-60000	word
	2335	091F	Motor current control authority	R	0-panel; 1-native; 2-COMM; 3-remote; 4-stop; 5-all	word
	2336-2340	0920-0924	Reserve	R		word
Record clear	2341	0925	Energy clear	W	Write data 0xa5b5	word
	2342	0926	Clear motor operation information	W	Write data 0xa5b5	word
	2343	0927	Event record clear	W	Write data 0xa5b5	word
System parameter	2350	092E	Current	R	1.6、6.3、25.0、100.0、250.0、800.0、1.0、5.0	word
	2351	092F	Current proportional factor	R	1、10、100	
	2352	0930	Operational control bits	R/W	1-Stop、2-start1、3-start2、4-Emergency stop、5-Reset	word
	2353	0931	Restore factory setting	R/W	Write data 0xFFFF	word
	2354	0932	Reserve	R	Reserve	word
	2355	0933	Input Mark of Residual Current Transformer	R/W	0 not input, 1 input	word
	2356	0934	Base Wave Switch	R/W	0 Rms, 1 Fundament	word
	2357	0935	Motor type	R/W	0 Common motor, 1 Increased safety motor	word
	2358	0936	CT Ratio	R/W	1A:1-5000 5A:1-1000 other specifications can not set CT ratio	word
	2359	0937	Rated Frequency	R/W	45-70Hz	word
	2360	0938	Motor rated current	R/W	1A:0.1-5000.0A 5A:0.5-5000.0A 1.6A:0.4-1.6A 6.3A:1.6-6.3A 25A:6.3-25.0A 100A:25.0-100.0A 250A:63.0-250.0A 800A:250.0-800.0A	word
	2361	0939	Motor rated voltage	R/W	57-1200	word
	2362	093A	Motor rated Power	R/W	High bit	word
	2363	093B		R/W	Low bit	word
2364	093C	Wiring	R/W	0:1P,1:3P4L, 2:3P3L	word	

	2365	093D	Back light	R/W	1-30s, 0:Normally on	word
	2366	093E	Liquid crystal contrast	R/W	0~100	word
	2367	093F	Main interface index	R/W	1-7 (0-20 can write)	word
	2368	0940	Language	R/W	0-Chinese, 1-English	word
	2369	0941	Current mask value	R/W	0-30	word
	2370	0942	Password	R/W	0000-9999	
	2371	0943	Reserve	R		
	2372	0944	Maximum time of running record	R/W	1-5hour	
	2373	0945	Analog output 1 setting	R/W	Type:0-Ia,1-Ib,2-Ic,3-Iav,4-Uab,5-Ubc,6-Uca,7-Uav,8-PTC,9-Heat capacity,10-P,11-F	word
	2374	0946	Analog output 1 full value	R/W	2 times rated current	word
	2375	0947		R/W		
	2376	0948	Analog output 2 setting	R/W	Type:0-Ia,1-Ib,2-Ic,3-Iav,4-Uab,5-Ubc,6-Uca,7-Uav,8-PTC,9-Heat capacity,10-P,11-F	
	2377	0949	Analog output 2 full value	R/W	2 times rated current	
	2378	094A		R/W		
	2379-2393	094B-0959	Reserve	R		word
	2394	095A	LCD version	R		word
	2395	095B	LCD NO.	R		word
	2396	095C	Module version	R		word
	2397	095D	Module NO.	R		word
	2398	095E	Main body version	R		word
	2399	095F	Main body NO.	R		word
Low speed protection	2400	0960	Trip allowed/forbidden 1	R/W	Bit0 reverse time overload trip Bit1 ground trip Bit2 under load trip Bit3 phase break trip Bit4 under voltage trip Bit5 over voltage trip Bit6 blocking trip Bit7 blocking trip Bit8 unbalanced trip Bit9 PTC temperature trip Bit10 external fault trip Bit11 start timeout trip	word

					Bit12 overpower trip Bit13 underpower trip Bit14 phase sequence trip Bit15 short circuit trip (0-not input,1-input)	
2401	0961	Trip allowed/forbidden 2	R/W	Bit0 constant time overload trip Bit1 voltage unbalance trip Bit2 overflow trip Bit3 insulation monitoring trip Bit4 start times trip Bit5 running time trip Bit6 failure times trip Bit7 leakage current trip (0-not input,1-input)	word	
2402	0962	Alarm allowed/forbidden 1	R/W	Bit0 reverse time overload alarm Bit1 ground alarm Bit2 under load alarm Bit3 phase break alarm Bit4 under voltage alarm Bit5 over voltage alarm Bit6 block turn alarm Bit7 blocking alarm Bit8 current imbalance alarm Bit9PTC temperature alarm Bit10 external fault alarm Bit11 start timeout alarm Bit12 overpower alarm Bit13 low power alarm Bit14 phase sequence alarm Bit15 short circuit alarm (0-not input,1-input)	word	
2403	0963	Alarm allowed/forbidden 2	R/W	Bit0 fixed time overload alarm Bit1 voltage imbalance alarm Bit2 overflow alarm Bit3 insulation monitoring alarm Bit4 start times alarm Bit5 running time alarm	word	

					Bit6 failure times alarm Bit7 leakage current alarm (0-not input,1-input)	
2404	0964	Trip level	R/W	1、2、3、5、10、15、20、 25、30、35、40	word	
2405	0965	tE time protection trip level	R/W	2、3、4、5、6、8、10、12、 15	word	
2406	0966	Start setting	R/W	100-800%	word	
2407	0967	Reset method	R/W	0-Off; 1-On	word	
2408	0968	Overload cooling time	R/W	0-30min	word	
2409	0969	Overload alarm threshold	R/W	1-99%	word	
2410	096A	Overload action stage	R/W	Bit0-stop; Bit1-start; Bit2-run (0-invalid; 1-valid)	word	
2411	096B	Overload starting screen time	R/W	0-25.0	word	
2412	096C	Ground fault alarm threshold	R/W	20%-100%		
2413	096D	Ground fault trip threshold	R/W	20%-100%		
2414	096E	Ground fault alarm delay	R/W	0.1~600.0s	word	
2415	096F	Ground fault protection delay	R/W	0.1~600.0s	word	
2416	0970	Ground fault protection action stage and trip mode	R/W	Bit0-stop; Bit1-start; Bit2-run (0-invalid; 1-valid) ; Bit8-(0- circuit breaker 1- contactor)	word	
2417	0971	Ground fault return coefficient and starting screen time	R/W	low byte:5%;high byte:0-25.0	word	
2418	0972	Leakage alarm threshold	R/W	(100~1000) mA	word	
2419	0973	Leakage trip threshold	R/W	(100~1000) mA	word	
2420	0974	Leakage alarm delay	R/W	0.1~600.0s		
2421	0975	Leakage trip delay	R/W	0.1~600.0s		
2422	0976	Leakage protection action stage and action selection	R/W	Bit0-stop; Bit1-start; Bit2-run (0-valid; 1-invalid) ; Bit8-action selection (0-trip circuit breaker 1-trip contactor)		
2423	0977	Leakage protection return coefficient and starting screen time	R/W	Low byte:5%;high byte:0-25.0		

2424	0978	under load alarm threshold	R/W	10~99%	
2425	0979	under load trip Threshold	R/W	10~99%	
2426	097A	under load alarm delay	R/W	0.1~600.0s	word
2427	097B	under load trip delay	R/W	0.1~600.0s	word
2428	097C	under load action stage	R/W	Bit0-stop; Bit1-start; Bit2-run (0-invalid; 1-valid)	
2429	097D	under load return coefficient	R/W	5%	
2430	097E	Reserve	R		
2431	097F	Reserve	R		word
2432	0980	Phase loss alarm delay	R/W	0.1~600.0s	word
2433	0981	Phase loss trip delay	R/W	0.1~600.0s	word
2434	0982	Phase loss action stage	R/W	Bit0-stop; Bit1-start; Bit2-run (0-invalid; 1-valid)	
2435	0983	Reserve	R		
2436	0984	Under voltage alarm threshold	R/W	50~90%	
2437	0985	Under voltage trip threshold	R/W	50~90%	word
2438	0986	Under voltage alarm delay	R/W	0.1~600.0s	word
2439	0987	Under voltage trip delay	R/W	0.1~600.0s	word
2440	0988	Under voltage action stage	R/W	Bit0-stop; Bit1-start; Bit2-run (0-invalid; 1-valid)	
2441	0989	Under voltage return coefficient	R/W	5%	word
2442	098A	Overvoltage alarm threshold	R/W	110~150%	
2443	098B	Overvoltage trip threshold	R/W	110~150%	
2444	098C	Overvoltage alarm delay	R/W	0.1~600.0s	word
2445	098D	Overvoltage trip delay	R/W	0.1~600.0s	word
2446	098E	Overvoltage action stage	R/W	Bit0-stop; Bit1-start; Bit2-run (0-invalid; 1-valid)	
2447	098F	Overvoltage return coefficient	R/W	5%	word
2448	0990	Locked-rotor alarm threshold	R/W	100~700%	
2449	0991	Locked-rotor trip threshold	R/W	100~700%	

2450	0992	Locked-rotor alarm delay	R/W	0.1~600.0s	word
2451	0993	Locked-rotor trip delay	R/W	0.1~600.0s	word
2452	0994	Reserve	R		
2453	0995	Locked-rotor return coefficient	R/W	5%	word
2454	0996	Block alarm threshold	R/W	100~700%	
2455	0997	Block trip threshold	R/W	100~700%	
2456	0998	Block alarm delay	R/W	0.1~600.0s	word
2457	0999	Block trip delay	R/W	0.1~600.0s	word
2458	099A	Reserve	R		
2459	099B	Block return coefficient	R/W	5%	word
2460	099C	Current unbalance alarm threshold	R/W	10~99%	
2461	099D	Current unbalance trip threshold	R/W	10~99%	
2462	099E	Current unbalance alarm delay	R/W	0.1~600.0s	word
2463	099F	Current unbalance trip delay	R/W	0.1~600.0s	word
2464	09A0	Current unbalance action stage	R/W	Bit0-stop; Bit1-start; Bit2-run (0-invalid; 1-valid)	
2465	09A1	Current unbalance return coefficient	R/W	5%	word
2466	09A2	NTC /PTC	R/W	0 NTC, 1PTC	
2467	09A3	Temperature protection alarm threshold	R/W	100~30000	
2468	09A4	Temperature protection trip threshold	R/W	100~30000	word
2469	09A5	Temperature protection Alarm delay	R/W	0.1~600.0s	word
2470	09A6	Temperature protection trip delay	R/W	0.1~600.0s	
2471	09A7	Temperature protection action stage	R/W	Bit0-stop; Bit1-start; Bit2-run (0-invalid; 1-valid)	word
2472	09A8	Temperature protection reset method	R/W	0-manual; 1-automatic	
2473	09A9	Temperature Return resistance value	R/W	0-close the function。 Setting range:100~30000	
2474	09AA	Reserve	R		
2475	09AB	External fault alarm delay	R/W	0.1~600.0s	word

2476	09AC	External fault trip delay	R/W	0.1~600.0s	word
2477	09AD	External fault action stage	R/W	Bit0-stop; Bit1-start; Bit2-run (0-invalid; 1-valid)	
2478	09AE	Start overtime action threshold	R/W	100%~200%	word
2479	09AF	Start time	R/W	0.1~600.0s	
2480	09B0	Over power alarm threshold	R/W	100~700%	
2481	09B1	Over power trip threshold	R/W	100~700%	word
2482	09B2	Over power alarm delay	R/W	0.1~600.0s	word
2483	09B3	Over power trip delay	R/W	0.1~600.0s	
2484	09B4	Over power action stage	R/W	Bit0-stop; Bit1-start; Bit2-run (0-invalid; 1-valid)	word
2485	09B5	Over power return coefficient	R/W	5%	
2486	09B6	Under power alarm threshold	R/W	0~100%	
2487	09B7	Under power trip threshold	R/W	0~100%	word
2488	09B8	Under power alarm delay	R/W	0.1~600.0s	word
2489	09B9	Under power trip delay	R/W	0.1~600.0s	
2490	09BA	Under power action stage	R/W	Bit0-stop; Bit1-start; Bit2-run (0-invalid; 1-valid)	word
2491	09BB	Under power return coefficient	R/W	5%	
2492	09BC	Reserve	R		
2493	09BD	Reserve	R		word
2494	09BE	Phase sequence alarm delay	R/W	0.1~600.0s	word
2495	09BF	Phase sequence trip delay	R/W	0.1~600.0s	
2496	09C0	Phase sequence action stage	R/W	Bit0-stop; Bit1-start; Bit2-run (0-invalid; 1-valid)	word
2497	09C1	Reserve	R		
2498	09C2	Short circuit protection alarm threshold in the start-up phase	R/W	400%~800%	
2499	09C3	Short circuit protection trip threshold in the start-up phase	R/W	400%~800%	word
2500	09C4	Short circuit protection	R/W	400%~800%	

		alarm threshold in the running phase			
2501	09C5	Short circuit protection trip threshold in the running phase	R/W	400%~800%	
2502	09C6	Short circuit protection alarm delay	R/W	0.1~600.0s	word
2503	09C7	Short circuit protection trip delay	R/W	0.1~600.0s	word
2504	09C8	Short circuit protection action stage	R/W	Bit0-stop; Bit1-start; Bit2-run (0-invalid; 1-valid)	word
2505	09C9	Short circuit protection return coefficient	R/W	5%	word
2506	09CA	Fixed time overload alarm threshold	R/W	100-800%	word
2507	09CB	Fixed time overload trip threshold	R/W	100-800%	
2508	09CC	Fixed time overload alarm delay	R/W	0.1~600.0s	
2509	09CD	Fixed time overload trip delay	R/W	0.1~600.0s	word
2510	09CE	Fixed time overload action stage	R/W	Bit0-stop; Bit1-start; Bit2-run (0-invalid; 1-valid)	word
2511	09CF	Fixed time overload return coefficient	R/W	5%	
2512	09D0	Voltage unbalance alarm threshold	R/W	10~99%	
2513	09D1	Voltage unbalance trip threshold	R/W	10~99%	
2514	09D2	Voltage unbalance alarm delay	R/W	0.1~600.0s	word
2515	09D3	Voltage unbalance trip delay	R/W	0.1~600.0s	
2516	09D4	Voltage unbalance action stage	R/W	Bit0-stop; Bit1-start; Bit2-run (0-invalid; 1-valid)	word
2517	09D5	Voltage unbalance return coefficient	R/W	5%	word
2518	09D6	Overflow protection threshold	R/W	400%~800%	
2519-2523	09D7-09DB	Reserve	R		
2524	09DC	Insulation monitoring alarm delay	R/W	0.1~600.0s	

	2525	09DD	Insulation monitoring trip delay	R/W	0.1~600.0s	
	2526	09DE	Insulation monitoring action stage	R/W	Bit0-stop; Bit1-start; Bit2-run (0-invalid; 1-valid)	word
Other alarm	2527	09DF	Start times protection alarm threshold	R/W	1-10 Unit:times	
	2528	09E0	Start times protection range	R/W	10-300min	
	2529	09E1	Running time alarm threshold	R/W	1000-60000 Unit:hour	
	2530	09E2	Running time action stage	R/W	Bit0-stop; Bit1-start; Bit2-run (0-invalid; 1-valid)	
	2531	09E3	Trip times protection alarm threshold	R/W	20-10000 Unit:times	
	2532	09E4	Trip times protection action stage	R/W	Bit0-stop; Bit1-start; Bit2-run (0-invalid; 1-valid)	
	2533-2599	09E5-0A27	Reserve	R		
High speed protection	2600	0A28	High speed trip allowed bit 1	R/W	The range of high speed protection is the same as low speed, but the default value is different	
	2601	0A29	High speed trip allowed bit 2	R/W		
	2602	0A2A	High speed alarm allowed bit 1	R/W		
	2603	0A2B	High speed alarm allowed bit 2	R/W		
	2604	0A2C	High speed rated current	R/W		
	2605	0A2D	High speed rated power	R/W		
	2606	0A2E		R/W		
	2607	0A2F	High speed trip level	R/W		
	2608	0A30	High speed tE trip level	R/W		
	2609	0A31	High speed overload start value	R/W		
	2610	0A32	High speed overload reset method	R/W		
	2611	0A33	High speed overload cooling time	R/W		
	2612	0A34	High speed overload alarm threshold	R/W		
	2613	0A35	High speed overload action stage	R/W		

2614	0A36	High speed starting screen time	R/W		
2615	0A37	High speed under load alarm threshold	R/W		
2616	0A38	High speed under load alarm threshold	R/W		
2617	0A39	High speed under load alarm delay	R/W		
2618	0A3A	High speed under load trip delay	R/W		
2619	0A3B	High speed under load action stage	R/W		
2620	0A3C	High speed under load return coefficient	R/W		
2621	0A3D	Reserve	R		
2622	0A3E	Reserve	R		
2623	0A3F	High speed phase loss alarm delay	R/W		
2624	0A40	High speed phase loss trip delay	R/W		
2625	0A41	High speed phase loss action stage	R/W		
2626	0A42	Reserve	R		
2627	0A43	High speed locked-rotor alarm threshold	R/W		
2628	0A44	High speed locked-rotor trip threshold	R/W		
2629	0A45	High speed locked-rotor alarm delay	R/W		
2630	0A46	High speed locked-rotor trip delay	R/W		
2631	0A47	Reserve	R		
2632	0A48	High speed locked-rotor return coefficient	R/W		
2633	0A49	High speed blocking alarm threshold	R/W		
2634	0A4A	High speed blocking trip threshold	R/W		
2635	0A4B	High speed blocking alarm delay	R/W		
2636	0A4C	High speed blocking trip delay	R/W		
2637	0A4D	Reserve	R		

2638	0A4E	High speed blocking return coefficient	R/W		
2639	0A4F	High speed current unbalance alarm threshold	R/W		
2640	0A50	High speed current unbalance trip threshold	R/W		
2641	0A51	High speed current unbalance alarm delay	R/W		
2642	0A52	High speed current unbalance trip delay	R/W		
2643	0A53	High speed current unbalance action stage	R/W		
2644	0A54	High speed current unbalance return coefficient	R/W		
2645	0A55	High speed start overtime action threshold	R/W		
2646	0A56	High speed start overtime time range	R/W		
2647	0A57	High speed over power alarm threshold	R/W		
2648	0A58	High speed over power trip threshold	R/W		
2649	0A59	High speed over power alarm delay	R/W		
2650	0A5A	High speed over power trip delay	R/W		
2651	0A5B	High speed over power action stage	R/W		
2652	0A5C	High speed over power return coefficient	R/W		
2653	0A5D	High speed under power alarm threshold	R/W		
2654	0A5E	High speed under power trip threshold	R/W		
2655	0A5F	High speed under power alarm delay	R/W		
2656	0A60	High speed under power trip delay	R/W		
2657	0A61	High speed under power action stage	R/W		

	2658	0A62	High speed under power return coefficient	R/W		
	2659	0A63	High speed short circuit starting stage alarm threshold	R/W		
	2660	0A64	High speed short circuit starting stage trip threshold	R/W		
	2661	0A65	High speed short circuit running stage alarm threshold	R/W		
	2662	0A66	High speed short circuit running stage trip threshold	R/W		
	2663	0A67	High speed short circuit alarm delay	R/W		
	2664	0A68	High speed short circuit trip delay	R/W		
	2665	0A69	High speed short circuit action stage	R/W		
	2666	0A6A	High speed short circuit return coefficient	R/W		
	2667	0A6B	High speed fixed time overload alarm threshold	R/W		
	2668	0A6C	High speed fixed time overload trip threshold	R/W		
	2669	0A6D	High speed fixed time overload alarm delay	R/W		
	2670	0A6E	High speed fixed time overload trip delay	R/W		
	2671	0A6F	High speed fixed time overload action stage	R/W		
	2672	0A70	High speed fixed time overload return coefficient	R/W		
	2673-2749	0A71-0ABD	Reserve	R		
Start control	2750	0ABE	Self start mode	R/W	0-start, 1-restore	word
	2751	0ABF	Self start delay	R/W	0.1~60.0s	word
	2752	0AC0	Self start control	R/W	0-off, 1-on	word
	2753	0AC1	Control permission setting	R/W	0-panel; 1-native; 2-COMM; 3-remote; 4-3	word

					choice 1; 5-2 choice1; 6-all control	
	2754	0AC2	3 choose 1 control permission programmable output 1	R/W	0-COMM; 1-native; 2-panel; 3-stop; 4-remote. default value:0	word
	2755	0AC3	3 choose 1 control permission programmable output 2	R/W	0-COMM; 1-native; 2-panel; 3-stop; 4-remote. default value:1	word
	2756	0AC4	3 choose 1 control permission programmable output 3	R/W	0-COMM; 1-native; 2-panel; 3-stop; 4-remote. default value:2	word
	2757	0AC5	3 choose 1 control permission programmable output 4	R/W	0-COMM; 1-native; 2-panel; 3-stop; 4-remote. default value:3	word
	2758	0AC6	Start mode	R/W	0-protection mode, 1-manual mode, 2-two-step start, 3-two speed mode, 4-Y-△ three relay mode, 5-self step-down three relay mode	word
	2759	0AC7	Start delay setting	R/W	0.1~60.0s	word
	2760	0AC8	Restore voltage setting	R/W	70~95%	word
	2761	0AC9	Immediately restart allowed time	R/W	0.1~10.0s	word
	2762	0ACA	Restart delay setting	R/W	1.0~60.0s	word
	2763	0ACB	Voltage shock start control	R/W	0:OFF, 1=restart on start1, 2=restart on start2	word
	2764	0ACC	Voltage shock maximum allowable time	R/W	0.5~300.0s	word
	2765	0ACD	Drop voltage setting		50-90% cannot be greater than restore voltage	
	2766-2794	0ACE-0AEA	Reserve	R		word
programmable setting	2800	0AF0	Relay initial state	R/W	0-normally on, 1-normally off; bit0-bit5 correspond to DO1-DO6	word
	2801	0AF1	DO1 programmable definition	R/W	0-not input、1-start1、2-start2、3-start3、4-Stop、5-trip contactor、6-trip breaker circuit、7-alarm output、8-trip output、9-stopping status output、10-starting status output、	

					11-running status output、 12-communication control output、 13-device self-check output、 14-device power output、 15-voltage shock interlocking output、 16-voltage shock reset signal output、 17-protection mode voltage shock output1、 18-protection mode voltage shock output2、 19-logic figure output 1、 20-logic figure output 2、 21-logic figure output 3、 22-31 correspond to DI1-10 control DO output.	
2802	0AF2	DO1 action setting (time)	R/W	0-level; (3-250) -pulse width, Unit:0.1S	word	
2803	0AF3	DO1 trip setting 1	R/W	Same as address 2400 settings	word	
2804	0AF4	DO1 trip setting 2	R/W	Same as address 2401 settings	word	
2805	0AF5	DO1 Alarm setting1	R/W	Same as address 2402 settings	word	
2806	0AF6	DO1 Alarm setting2	R/W	Same as address 2403 settings	word	
2807	0AF7	DO2 programmable definition	R/W	The same as DO1 (2801-2806)	word	
2808	0AF8	DO2 action setting (time)	R/W		word	
2809	0AF9	DO2 trip setting 1	R/W		word	
2810	0AFA	DO2 trip setting 2	R/W		word	
2811	0AFB	DO2 Alarm setting1	R/W		word	
2812	0AFC	DO2 Alarm setting2	R/W		word	
2813	0AFD	DO3 programmable definition	R/W	The same as DO1 (2801-2806)	word	
2814	0AFE	DO3 action setting (time)	R/W		word	
2815	0AFF	DO3 trip setting 1	R/W		word	
2816	0B00	DO3 trip setting 2	R/W		word	
2817	0B01	DO3 Alarm setting1	R/W		word	
2818	0B02	DO3 Alarm setting2	R/W		word	
2819	0B03	DO4 programmable	R/W	The same as DO1	word	

		definition		(2801-2806)	
2820	0B04	DO4 action setting (time)	R/W		word
2821	0B05	DO4 trip setting 1	R/W		word
2822	0B06	DO4 trip setting 2	R/W		word
2823	0B07	DO4 Alarm setting1	R/W		word
2824	0B08	DO4 Alarm setting2	R/W		word
2825	0B09	DO5 programmable definition	R/W	The same as DO1 (2801-2806)	word
2826	0B0A	DO5 action setting (time)	R/W		word
2827	0B0B	DO5 trip setting 1	R/W		word
2828	0B0C	DO5 trip setting 2	R/W		word
2829	0B0D	DO5 Alarm setting1	R/W		word
2830	0B0E	DO5 Alarm setting2	R/W		word
2831	0B0F	DO6 programmable definition	R/W	The same as DO1 (2801-2806)	word
2832	0B10	DO6 action setting (time)	R/W		word
2833	0B11	DO6 trip setting 1	R/W		word
2834	0B12	DO6 trip setting 2	R/W		word
2835	0B13	DO6 Alarm setting1	R/W		word
2836	0B14	DO6 Alarm setting2	R/W		word
2837-2 860	0B15-0 B2C	Reserve	R	Reserve for DO7-10	
2861	0B2D	DI normally ON/OFF setting	R/W	Bit0-Bit9 correspond to DI1-10, 0-normally on; 1-normally off	
2862	0B2E	DI1 programmable definition	R/W	1-common DI, 2-start1(native), 3-start1(remote), 4-start2(native), 5-start2(remote), 6-Stop(native), 7-Stop(remote), 8-Reset, 9-emergency stop, 10-external fault, 11-single point 1 (in situ) start-stop, 12-single point 1 (remote) start-stop, 13-single point 2 (in situ) start-stop, 14-single point 2 (remote) start-stop,	word

					15-single point 1 start/stop, 16-single point 2 start/stop, 17-control over 1, 18-control over 2	
2863	0B2F	DI2 programmable definition	R/W	Ditto		word
2864	0B30	DI3 programmable definition	R/W			word
2865	0B31	DI4 programmable definition	R/W			word
2866	0B32	DI5 programmable definition	R/W			word
2867	0B33	DI6 programmable definition	R/W			word
2868	0B34	DI7 programmable definition	R/W			word
2869	0B35	DI8 programmable definition	R/W			word
2870	0B36	DI9 programmable definition	R/W			word
2871	0B37	DI10 programmable definition	R/W			word
2872-2 877	0B38-0 B3D	Reserve	R			Reserve for DI11-16
2878	0B3E	Logic figure input definition 1	R/W	0-OFF;1-A;2-A*B;3-A+B;4 -A*B*C;5-(A+B)*C;6-(A*B) +C;7-A+B+C;8-A*B*C*D; 9-(A+B)*C*D;10-(A*B+C) *D;11-(A+B+C)*D;12-A*B *C+D;13-(A+B)*C+D;14-A *B+C+D;15-A+B+C+D;16- A*B*C*D+E;17-(A+B)*C* D+E;18-(A*B+C)*D+E;19-(A+B+C)*D+E;20-(A*B*C+ D)*E;21-((A+B)*C+D)*E;2 2-(A*B+C+D)*E;23-(A+B+ C+D)*E;24-A*B*C*D+E;2 5-(A+B)*C*D+E;26-(A*B+ C)*D+E;27-(A+B+C)*D+E; 28-A*B*C+D+E;29-(A+B)* C+D+E;30-A*B+C+D+E;31 -A+B+C+D+E	word	
2879	0B3F	Input condition A	R/W	Low byte:0-Off; 1-10 correspond to DI1-10; 17-22	word	

					correspond to DO1-DO6; 27-start1; 28-start2; 29-start3; 30-Stop; 31-Emergency stop; 32-stop status; 33-start status; 34-run status; 35-alarm status; 36-trip status; 49-80 correspond to trip; 81-112 correspond to Alarm High byte:0-positive logic1-anti-logic	
2880	0B40	Input condition B	R/W	The same as address 2879	word	
2881	0B41	Input condition C	R/W		word	
2882	0B42	Input condition D	R/W		word	
2883	0B43	Input condition E	R/W		word	
2884	0B44	Input A delay	R/W	0.0-60.0s	word	
2885	0B45	Input B delay	R/W	0.0-60.0s	word	
2886	0B46	Input C delay	R/W	0.0-60.0s	word	
2887	0B47	Input D delay	R/W	0.0-60.0s	word	
2888	0B48	Input E delay	R/W	0.0-60.0s	word	
2889	0B49	Logic figure input definition 2	R/W	The same as logic figure input definition 1 (address:2878~2888)	word	
2890	0B4A	Input condition A	R/W		word	
2891	0B4B	Input condition B	R/W		word	
2892	0B4C	Input condition C	R/W		word	
2893	0B4D	Input condition D	R/W		word	
2894	0B4E	Input condition E	R/W		word	
2895	0B4F	Input A delay	R/W		word	
2896	0B50	Input B delay	R/W		word	
2897	0B51	Input C delay	R/W		word	
2898	0B52	Input D delay	R/W		word	
2899	0B53	Input E delay	R/W	word		
2900	0B54	Logic figure input definition 3	R/W	The same as logic figure input definition 1 (Address 2878~2888)	word	
2901	0B55	Input condition A	R/W		word	
2902	0B56	Input condition B	R/W		word	
2903	0B57	Input condition C	R/W		word	
2904	0B58	Input condition D	R/W		word	
2905	0B59	Input condition E	R/W		word	
2906	0B5A	Input A delay	R/W		word	
2907	0B5B	Input B delay	R/W	word		

	2908	0B5C	Input C delay	R/W		word
	2909	0B5D	Input D delay	R/W		word
	2910	0B5E	Input E delay	R/W		word
	2911-2919	0B5F-0B67	Reserve	R		word
COM M setting	2920	0B68	MODBUS RTU 1 address setting	R/W	1~247	word
	2921	0B69	MODBUS RTU 1 baud rate setting	R/W	0-38400,1-19200,2-9600,3-4800,4-2400,5-1200	word
	2922	0B6A	MODBUS RTU 1 parity bit	R/W	0-No check, 1-2stop bit, 3-Odd, 4-Even	word
	2923	0B6B	MODBUS RTU 2 address setting	R/W	1~247	word
	2924	0B6C	MODBUS RTU 2 baud rate setting	R/W	0-38400,1-19200,2-9600,3-4800,4-2400,5-1200	word
	2925	0B6D	MODBUS RTU 2 parity bit	R/W	0-No check, 1-2stop bit, 3-Odd, 4-Even	word
	2926	0B6E	Profibus module 1 address	R/W	1-126	word
	2927	0B6F	Profibus module 2 address	R/W	1-126	word
	2928	0B70	MODBUS TCP IP	R/W	The first 2 bytes of IP address,high byte first.	word
	2929	0B71	MODBUS TCP IP	R/W	The last 2 bytes of IP address,high byte first.	word
	2930	0B72	MODBUS TCP mask	R/W	The first 2 bytes of mask,high byte first.	word
	2931	0B73	MODBUS TCP mask	R/W	The last 2 bytes of mask,high byte first.	word
	2932	0B74	MODBUS TCP gateway	R/W	The first 2 bytes of gateway,high byte first.	word
	2933	0B75	MODBUS TCP gateway	R/W	The last 2 bytes of gateway,high byte first.	word
	2934	0B76	MODBUS TCP port number	R/W	0-65535	word
	2935	0B77	MODBUS TCP DHCP	R/W	0-off, 1-on	word
	2936	0B78	DNS	R/W	Reserve, same as IP	word
	2937	0B79	DNS	R/W	Reserve, same as IP	word
	2938	0B7A	MAC	R	First 2 bytes, high byte first	word
	2939	0B7B	MAC	R	Middle 2 bytes, high byte first	word
2940	0B7C	MAC	R	Last 2 bytes, high byte first	word	

	2941	0B7D	Reserve	R		word
	2942	0B7E	Reserve	R		word
	2942	0B7F	Profinet IP address	R/W	The first 2 bytes of IP address,high byte first.	word
	2943	0B80		R/W	The last 2 bytes of IP address,high byte first.	word
	2944	0B81	Profinet MAC address		First 2 bytes, high byte first	word
	2945	0B82			Middle 2 bytes, high byte first	word
	2946	0B83			Last 2 bytes, high byte first	word
	2947-2966	0B84-0B96	Profinet Name		40 character	word
	2967	0B97	Profinet status		Reserve 0F0F means normal 01 initialization,03 parameter,07 configurable,0F exchange	word
	2968-2969	0B98-0B99	Reserve	R		
	2970	0B9A	WIFI mode	R/W	0=STA site、1=AP hot spot、2=AP+STA	
	2971	0B9B	WIFI mode AP IP address	R/W	Same as modbus tcp Open hot spot, set by browser	
	2972	0B9C		R/W		
	2973	0B9D	WIFI mode STA IP address			
	2974	0B9E				
	2975	0B9F	WIFI port number	R/W	1-65535	
	2976-2987	0BA0-0BAB	WIFI mode AP SSID	R/W	24 characters maximum	
	2988-2997	0BAC-0BB5	WIFI mode AP password	R/W	20 characters maximum	
	3000	0BB8	DI NO.	R	0-9 correspond to DI1-10	
DI displacement record 1	3001	0BB9	DI status	R	0-on 1-off	
	3002	0BBA	Action 1time-year month	R	High byte:year,low byte:month	
	3003	0BBB	Action 1time-day hour	R	High byte:day,low byte:hour	
	3004	0BBC	Action 1time-minute second	R	High byte:minute,low byte:second	
	3005-3007	0BBD-0BBF	Reserve	R		
DI displacement	3008-3014	0BC0-0BC6	Ditto	R	Ditto	
	3015-3	0BC7-		R		

record 2-8	021	0BCD				
	3022-3 028	0BCE- 0BD4		R		
	3029-3 035	0BD5- 0BDB		R		
	3036-3 042	0BDC- 0BE2		R		
	3043-3 049	0BE3-0 BE9		R		
	3050-3 056	0BEA- 0BF0		R		
	3057-3 063	0BF1-0 BF7		R		
	3064-3 159	0BF8-0 C57	Reserve	R		
Start recordi ng1	3200	0C80	Start position	R	0-External start 1-COMM 2-native 3-panel 4-remote 5-self start 6-restart	
	3201	0C81	Maximum current when starting	R	Unit:1%	
	3202	0C82	Minimum voltage when starting	R	Unit:1%	
	3203	0C83	Start successful or not	R	1-stop when starting 2-enter running status 3-enter trip status	
	3204	0C84	Action 1 time-year month	R	High byte:year,low byte:month	
	3205	0C85	Action 1 time-day hour	R	High byte:day,low byte:hour	
	3206	0C86	Action 1 time-minute second	R	High byte:minute,low byte:second	
	3207	0C87	Start time	R	Unit:0.1S	
Start recordi ng2-8	3208-3 215	0C88-0 C8F	Ditto	R	Ditto	
	3216-3 223	0C90-0 C97		R		
	3224-3 231	0C98-0 C9F		R		
	3232-3 239	0CA0- 0CA7		R		
	3240-3 247	0CA8- 0CAF		R		
	3248-3 255	0CB0- 0CB7		R		

	3256-3 263	0CB8- 0CBF		R		
	3264-3 399	0CC0- 0D47	Reserve	R		
Stop record 1	3400	0D48	Stop position	R	0-external stop 1-COMM 2-native 3-panel 4-remote 5-emergency stop 6-trip 7-voltage shock stop	
	3401	0D49	Action 1time-year month	R	High byte:year,low byte:month	
	3402	0D4A	Action 1time-day hour	R	High byte:day,low byte:hour	
	3403	0D4B	Action 1time-minute second	R	High byte:minute,low byte:second	
	3404-3 407	0D4C- 0D4F	Reserve	R		
Stop record 2-8	3408-3 415	0D50-0 D57	Ditto	R	Ditto	
	3416-3 423	0D58-0 D5F		R		
	3424-3 431	0D60-0 D67		R		
	3432-3 439	0D68-0 D6F		R		
	3440-3 447	0D70-0 D77		R		
	3448-3 455	0D78-0 D7F		R		
	3456-3 463	0D80-0 D87		R		
	3464-3 599	0D88-0 E0F	Reserve	R		
Restart recordi ng1	3600	0E10	Reason for voltage shock	R	0-all three phase lose power 1-A phase 2-B phase 3-C phase	
	3601	0E11	Minimum voltage	R	Unit:1%	
	3602	0E12	Voltage shock time		Unit:0.1S	
	3603	0E13	Action after voltage shock		1-maintain 2-restart 1 3-restart 2	
	3604	0E14	Action time-year month	R	High byte:year,low byte:month	
	3605	0E15	Action time-day hour	R	High byte:day,low byte:hour	
	3606	0E16	Action time-minute second	R	High byte:minute,low byte:second	

	3607	0E17	Reserve	R		
Restart record 2-8	3608-3 615	0E18-0 E1F	Ditto	R	Ditto	
	3616-3 623	0E20-0 E27		R		
	3624-3 631	0E28-0 E2F		R		
	3632-3 639	0E30-0 E37		R		
	3640-3 647	0E38-0 E3F		R		
	3648-3 655	0E40-0 E47		R		
	3656-3 663	0E48-0 E4F		R		
	3704-3 799	0E78-0 ED7	Reserve	R		
Parame ter change record 1	3800	0ED8	Change time-year month	R		
	3801	0ED9	Change time-day hour	R		
	3802	0EDA	Change time-minute second	R		
	3803	0EDB	First communication address	R		
	3804	0EDC	Length of communication address	R		
	3805	0EDD	Setting method	R	0=lcd,1=rs485-1,2=rs485-2, 3=comm module	
Parame ter change record 2-8	3806-3 811	0EDE- 0EE3	Ditto	R	Ditto	
	3812-3 817	0EE4-0 EE9		R		
	3818-3 823	0EEA- 0EEF		R		
	3824-3 829	0EF0-0 EF5		R		
	3830-3 835	0EF6-0 EFB		R		
	3836-3 841	0EFC- 0F01		R		
	3842-3 847	0F02-0 F07		R		
	3848-3 919	0F08-0 F4F	Reserve	R		

Power on record1	3920	0F50	Power on index	R	Record the number of power on	
	3921	0F51	Power on time-year month	R	High byte:year,low byte:month	
	3922	0F52	Power on time-day hour	R	High byte:day,low byte:hour	
	3923	0F53	Power on time-minute second	R	High byte:minute,low byte:second	
Power on record 2-8	3924-3 927	0F54-0 F57	Ditto		Ditto	
	3928-3 931	0F58-0 F5B				
	3932-3 935	0F5C-0 F5F				
	3936-3 939	0F60-0 F63				
	3940-3 943	0F64-0 F67				
	3944-3 947	0F68-0 F6B				
	3948-3 951	0F6C-0 66F				
Power off record 1	3952	0F70	Power off index	R	Record the number of power off	
	3953	0F71	Power off time-year month	R	High byte:year,low byte:month	
	3954	0F72	Power off time-day hour	R	High byte:day,low byte:hour	
	3955	0F73	Power off time-minute second	R	High byte:minute,low byte:second	
Power off record 2-8	3956-3 959	0F74-0 F77	Ditto		Ditto	
	3960-3 963	0F78-0 F7B				
	3964-3 967	0F7C-0 F7F				
	3968-3 971	0F80-0 F83				
	3972-3 975	0F84-0 F87				
	3976-3 979	0F88-0 F8B				
	3980-3 983	0F8C-0 F8F				
	3984-3	0F90-0	Reserve	R		

	989	F95				
	3990-3 995	0F96-0 F9B	Internal Reserve	R		
Fault record 1	4000	0FA0	Fault trip status 1	R		
	4001	0FA1	Fault trip status 2	R		
	4002	0FA2	Fault alarm status 1	R		
	4003	0FA3	Fault alarm status 2	R		
	4004	0FA4	Action 1time-year month	R	High byte:year,low byte:month	
	4005	0FA5	Action 1time-day hour	R	High byte:day,low byte:hour	
	4006	0FA6	Action 1time-minute second	R	High byte:minute,low byte:second	
	4007	0FA7	Fundamental wave switch、 sensor type	R	bit0: fundamental wave switch; bit1:PTC/NTC type	
	4008	0FA8	A phase current	R		
	4009	0FA9	B phase current	R		
	4010	0FAA	C phase current	R		
	4011	0FAB	A phase current	R		
	4012	0FAC	B phase current	R		
	4013	0FAD	C phase current	R		
	4014	0FAE	A phase current total harmonic content	R		
	4015	0FAF	B phase current total harmonic content	R		
	4016	0FB0	C phase current total harmonic content	R		
	4017	0FB1	A phase voltage total harmonic content	R		
	4018	0FB2	B phase voltage total harmonic content	R		
	4019	0FB3	C phase voltage total harmonic content	R		
	4020	0FB4	Total apparent power	R		
	4021	0FB5		R		
	4022	0FB6	Total active power	R		
	4023	0FB7		R		
	4024	0FB8	Total reactive power	R		
	4025	0FB9		R		
	4026	0FBA	Total power factor	R		
4027	0FBB	Frequency	R			

	4028	0FBC	Zero sequence current	R		
	4029	0FBD	Zero sequence voltage	R		
	4030	0FBE	PTC/NTC resistance	R		
	4031	0FBF	Leakage current	R		
	4032	0FC0	DI status	R		
	4033	0FC1	DO status	R		
	4034	0FC2	Motor status	R	Bit1 stop; Bit2 start; Bit3 run; Bit4 alarm	
	4035-4 049	0FC3-0 FD1	Reserve	R		
Fault record 2-8	4050-4 099	0FD2-1 003	Ditto	R	Ditto	
	4100-4 149	1004-1 035		R		
	4150-4 199	1036-1 067		R		
	4200-4 249	1068-1 099		R		
	4250-4 299	109A-1 0CB		R		
	4300-4 349	10CC- 10FD		R		
	4350-4 399	10FE-1 12F		R		
	4400-4 999	1130-1 387	Reserve	R		
custom ize mailing adress	5000	1388	correspond to value of custom address 1	R	As same as the correspond to mailing address	
	5001	1389	correspond to value of custom address 2	R		
	~	~	~	R		
	5119	144F	correspond to value of custom address 120	R		
	5120-5 299	1450-1 4B3	Reserve	R		
	5300	14B4	correspond to address of custom address 1	R/W		
	~	~	~	R/W		
5419	157B	correspond to address of custom address 120	R/W			
	5420-9 999	157C-2 70F	Reserve	R		
First 1	10000	2710	UAB maximum value			

minute running record			per minute			
	10001	2711	UAB average value per min			
	10002	2712	UAB minimum value per min			
	10003	2713	UBC maximum value per minute			
	10004	2714	UBC average value per min			
	10005	2715	UBC minimum value per min			
	10006	2716	UCA maximum value per minute			
	10007	2717	UCA average value per min			
	10008	2718	UCA minimum value per min			
	10009	2719	IA maximum value per minute			
	10010	271A	IA average value per min			
	10011	271B	IA minimum value per min			
	10012	271C	IB maximum value per minute			
	10013	271D	IB average value per min			
	10014	271E	IB minimum value per min			
	10015	271F	IC maximum value per minute			
	10016	2720	IC average value per min			
	10017	2721	IC minimum value per min			
	10018	2722	Leakage current			
	10019	2723	Frequency			
	10020	2724	Total active power			
	10021	2725	Total reactive power			
	10022	2726	Power factor			
	10023	2727	Switch input			
10024	2728	Relay output				
10025-	2729-2	Reserve		R		

	10029	72D				
2-300 minute running record	10030- 18999	272E-4 A37	Ditto		Ditto	
	19000- 19999	4A38-4 E1F	Reserve	R		
Wavefo rm record	20000- 20004	4E20-4 E24	Fault waveform 1	Record time (year month)	R	
				Record time (day hour)	R	
				Record time (minute second)	R	
				Fault status 1	R	
				Fault status 2	R	
	20005- 20009	4E25-4 E29	Fault waveform 2	R		
	~		Fault waveform 3-49, every 5 addresses for one group			
	20245-202 49	4F 15- 4F 19	Fault waveform 50	R		
	20250-209 59	4F 1A -51 DF	Reserve	R		
20960-209 61	51 E0- 51 E1	Voltage gain factor UA	R	FLOAT, High byte before, low byte after Sample point multiplied by gain factor=waveform actual value		
20962-209 63	51 E2- 51	Voltage gain factor UB	R	FLOAT		

Data block1		E3				
	20964-20965	51 E4- 51 E5	Voltage gain factor UC	R	FLOAT If wiring is 3P3L, waveform coefficient should make UA UC (UA+UC)/2 as UAB UBC UCA coefficient to show waveform	
	20966-20967	51 E6- 51 E7	Current gain factor IA	R	FLOAT	
	20968-20969	51 E8- 51 E9	Current gain factor IB	R	FLOAT	
	20970-20971	51 EA -51 EB	Current gain factor IC	R	FLOAT	
	20972-20973	51 EC -51 ED	Current gain factor IN	R	FLOAT	
	20974	51 EE	Time of occurrence(year month)	R	BCD	
	20975	51 EF	Time of occurrence(day hour)	R	BCD	
	20976	51 F0	Time of occurrence(minute second)	R	BCD	
	20977	51 F1	Time of occurrence(millisecond)	R		word
	20978	51 F2	Frequency	R		word
	20979	51 F3	Phase	R		word
	20980-20997	51 F4- 520 5				
	20998	520 6	The location where the next disturbance record entry will be stored	R		word
20999	520	Locate the current fault	R/W	Write 0-49,when the high	word	

		7	waveform position		byte is 80,it means that the recording data has been loaded		
Waveform 1	21000-21007	520 8-5 20 F	Data block 1	Wave record point 1-UA	R	-32767~32767	word
				Wave record point 1-UB	R	-32767~32767	word
				Wave record point 1-UC	R	-32767~32767	word
				Wave record point 1-IA	R	-32767~32767	word
				Wave record point 1-IB	R	-32767~32767	word
				Wave record point 1-IC	R	-32767~32767	word
				Wave record point 1-IN	R	-32767~32767	word
				Wave record point 1-switch input	R	bit15=DI10,bit6=DI1,bit5=DO6,bit0=DO1	word
	21008-21015	521 0-5 217	Wave record point 2	R		word	
	~		Wave record point 3-31, each group of data block contains 8 addresses	R		word	
21248-21255	530 0-5 307	Wave record point 32	R		word		
21256	530 8	Fault information 1			word		

	21257	530 9		Fault information 2			word
	21258	530 A		Frequency			word
	21259	530 B		Waveform position information		1-60000	word
	21260	530 C		Fault time(year month)			word
	21261	530 D		Fault time(day hour)			word
	21262	530 E		Fault time(minute second)			word
	21263	530 F		Data check, cumulative value of 0-262			word
	21264-212 71	531 0-5 317		Wave record point 33			word
	~			Wave record point 33-63, each group of data block contains 8 addresses			word
	21512-215 19	540 8-5 40 F	Data block 2	Wave record point 64			word
	21520	541 0		Fault information 1			word
	21521	541 1		Fault information 2			word
	21522	541 2		Phase line			word
	21523	541		Waveform			word

		3		position information			
	21524	541 4		Fault time(year month)			word
	21525	541 5		Fault time(day hour)			word
	21526	541 6		Fault time(minute second)			word
	21527	541 7		Data check, cumulative value of 0-262			word
	21528-21535	541 8-5 41 F		Wave record point 65			word
	~			Wave record point 66-95, each group of data block contains 8 addresses			word
	21776-21783	551 0-5 517		Wave record point 96			word
	21784	551 8	Data block 3	Fault information 1			word
	21785	551 9		Fault information 2			word
	21786	551 A		Phase line			word
	21787	551 B		Waveform position information			word
	21788	551 C		Fault time(year month)			word
	21789	551		Fault			word

		D		time(day hour)			
21790		551 E		Fault time(minute second)			word
21791		551 F		Data check, cumulative value of 0-262			word
21792-217 99		552 0-5 527		Wave record point 97			word
~				Wave record point 98-127, each group of data block contains 8 addresses			word
22040-220 47		561 8-5 61 F		Wave record point 128			word
22048		562 0	Data block4	Fault information 1			word
22049		562 1		Fault information 2			word
22050		562 2		Phase line			word
22051		562 3		Waveform position information			word
22052		562 4		Fault time(year month)			word
22053		562 5		Fault time(day hour)			word
22054		562 6		Fault time(minute second)			word

	22055	562 7		Data check, cumulative value of 0-262		word
Waveform 2	22056-231 11	562 8-5 A4 7	Ditto		R	Each waveform contains 128 addresses, divide into 4 blocks, each block contains 32 points and correspond to system information
Waveform 3-19	~		Ditto		R	Every 264*4=1056 occupy a waveform address
Waveform 20	41064-421 19	A0 68- A4 87	Ditto		R	word

9、Typical applications

9.1 ARD3M Electrical Motor Protection Mode Wiring

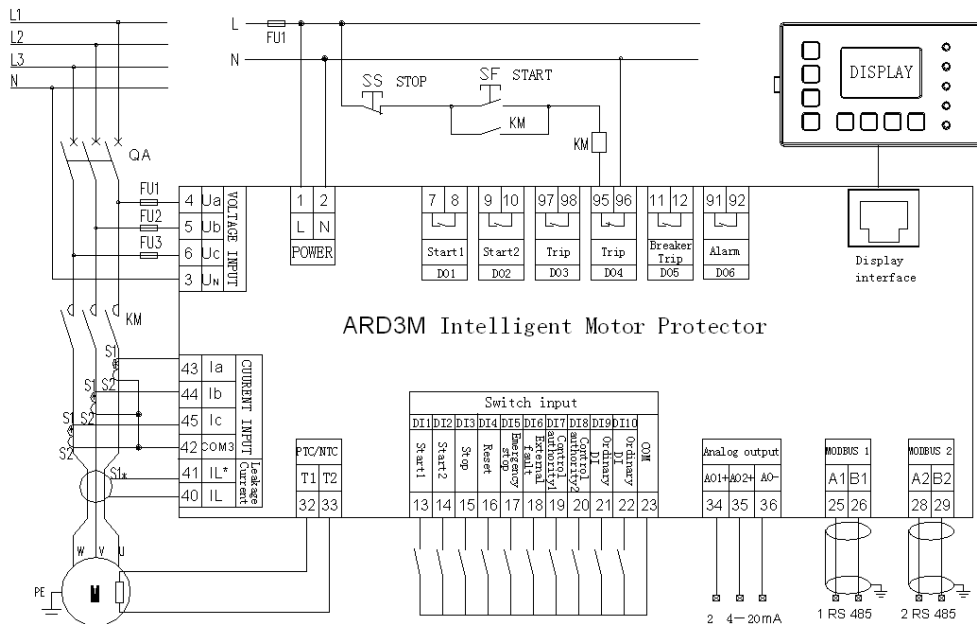

Protection mode: the starting and stopping of the motor is realized by the external button. The closing QA, presses the starting button SF, KM attracts the coil to get electricity, makes the main contact of the KM close, and the motor starts to work. When the stop button is pressed, the KM suction coil loses power, so that the main contact of the KM is released and the motor stops working.

9.2 ARD3M Electrical motor protector direct starting wiring diagram

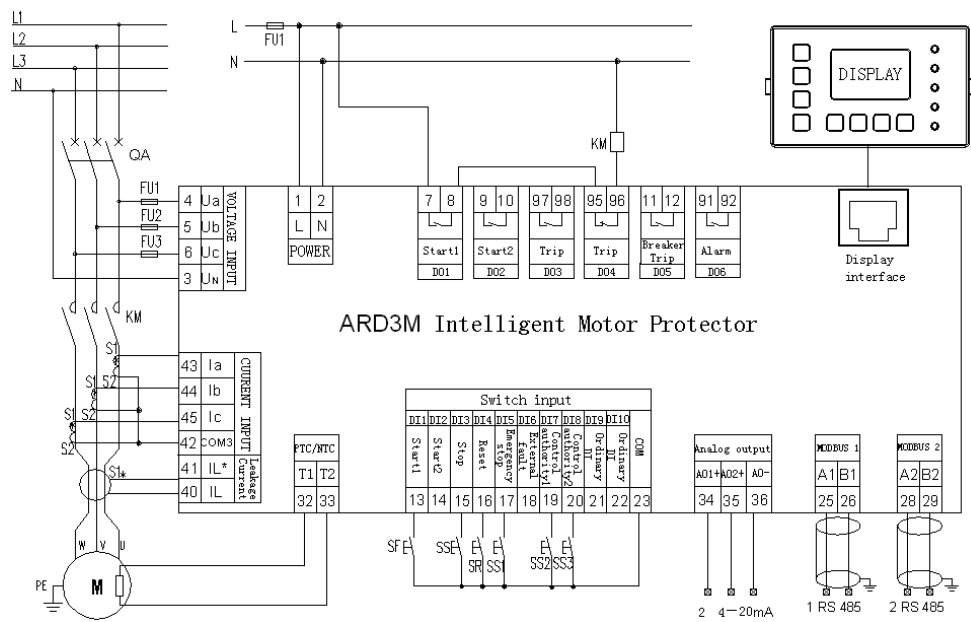

Direct starting: motor starting and stopping is controlled by protector, Press the Start 1 button on the display unit, Display unit control), DO1 relay (default start 1 function) closed, Close the KM's main contacts, The motor began to work. Press the "Stop" button on the panel, Local control), DO1 relay disconnect, with parking in this mode KM coil is out of power, The motor stopped working.

Press switch input DI1(default start 1 function, start control set to manual mode, local control), DO1 relay (default start 1 function) closed, so that the main contact of the KM closed, the motor began to work. Press switch input DI3(default stop function, start control set to manual mode, local control), DO1 relay disconnect 3S,KM coil power loss, motor stop work.

9.3 ARD3M Electrical motor protector forward/reverse (pulse output mode) wiring diagram

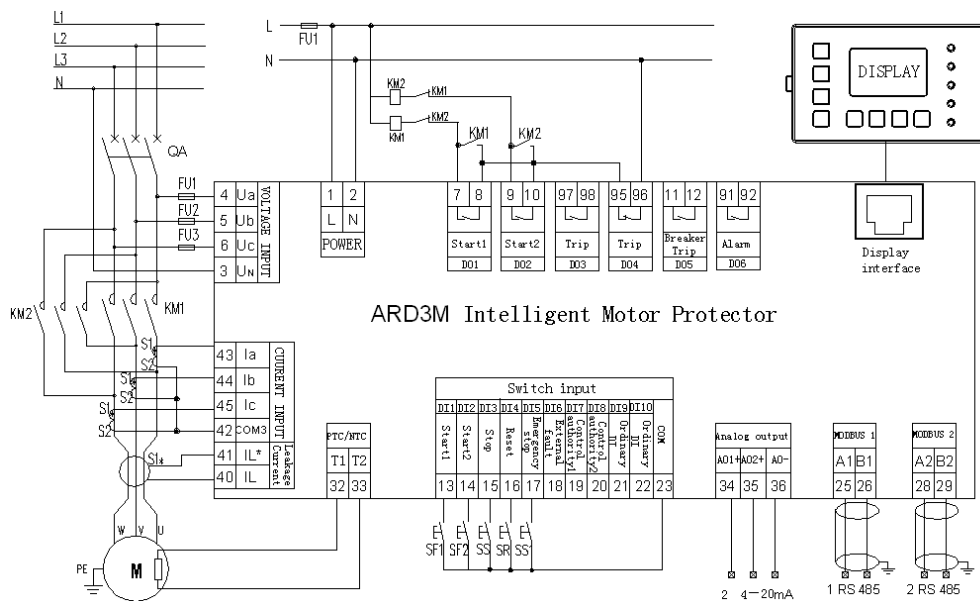

Forward and reverse starting: motor starting and stopping are controlled by protector, Press the Start 1 button on the display unit, Display unit control), DO1 relay (default start 1 function) closed,

Close the KM1's main contacts, Motor starting; Press the "start 2" button on the display unit, DO1 relay (default start 1 function) disconnected, DO2 relay (default start 2 function) closed, Close the KM2's main contacts, Motor reverse start. Press the stop button on the panel, DO2 relay, disconnect, KM1、KM2 coil is out of power, The motor stopped working.

Click switch input DI1(default start 1 function, Start control set to manual mode, Local control), DO1 relay (default start 1 function) closed, Close the KM1's main contacts, Motor starting; Click switch input DI2(default start 2 function), DO1 relay (default start 1 function) disconnected, DO2 relay (default start 2 function) closed, Close the KM2's main contacts, Motor reverse start. Click switch input DI3(default stop function), DO2 relay disconnected, KM1、KM2 coil is out of power, The motor stopped working.

9.4 ARD3M Electrical Motor Protector Y- Δ Starting (Two Relay Mode) Wiring Diagram

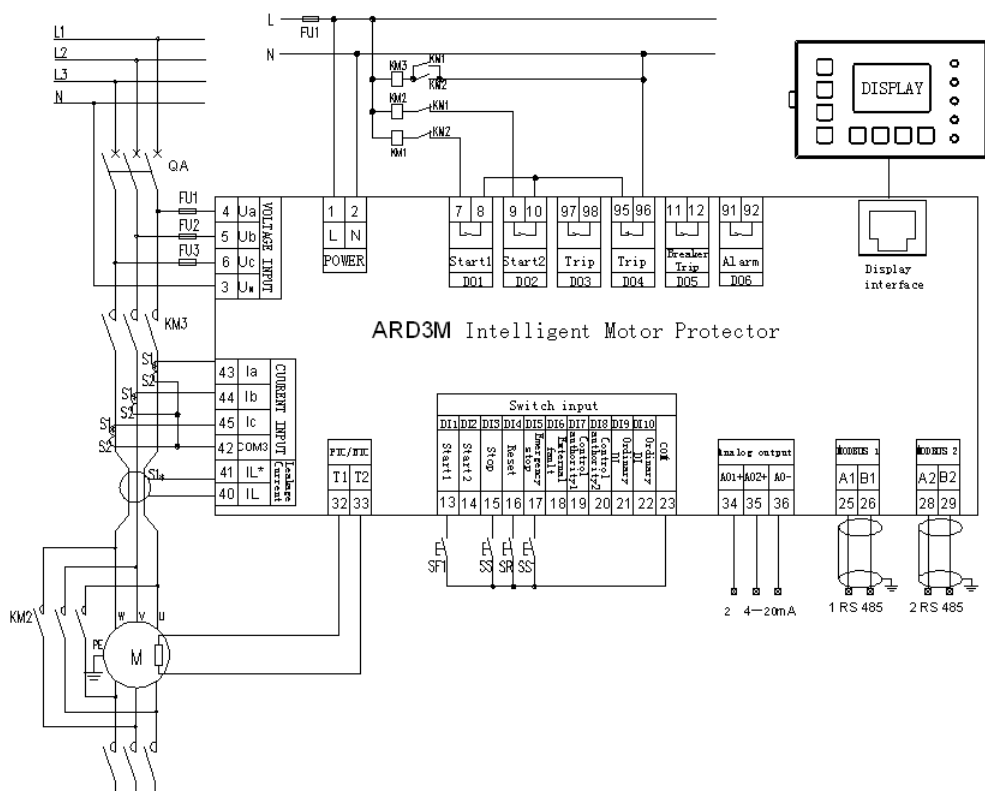

Y- Δ start (two relay mode): motor start, stop is controlled by protector, Press the "Start 1" button on the display unit, Display unit control), DO1 relay (default start 1 function) closed, Close the KM1、KM3's main contacts, Motor Y starting, After conversion time DO1 relay disconnected, DO2 relay closed (default start 2 function), Close the KM2、KM3's main contacts, Motor into Δ operation. Press the stop button on the panel, DO2 relay (default start 2 function) disconnected, KM1、KM2、KM3 coil is out of power, The motor stopped working.

Click switch input DI1(default start 1 function, Starting control is set to two-step mode, Local control), DO1 relay (default start 1 function) closed, Close the KM1、KM3's main contacts, Y motor starts, After conversion time DO1 relay disconnected, DO2 relay closed (default start 2 function), Close the KM2、KM3's main contacts, Motor into Δ operation. Click switch input DI3(default stop function), DO2 relay (default start 2 function) disconnected, KM1、KM2、KM3 coil is out of power, The motor stopped working.

9.5 ARD3M Electrical Protector Y-△ Starting (Three Relay Mode) Wiring Diagram

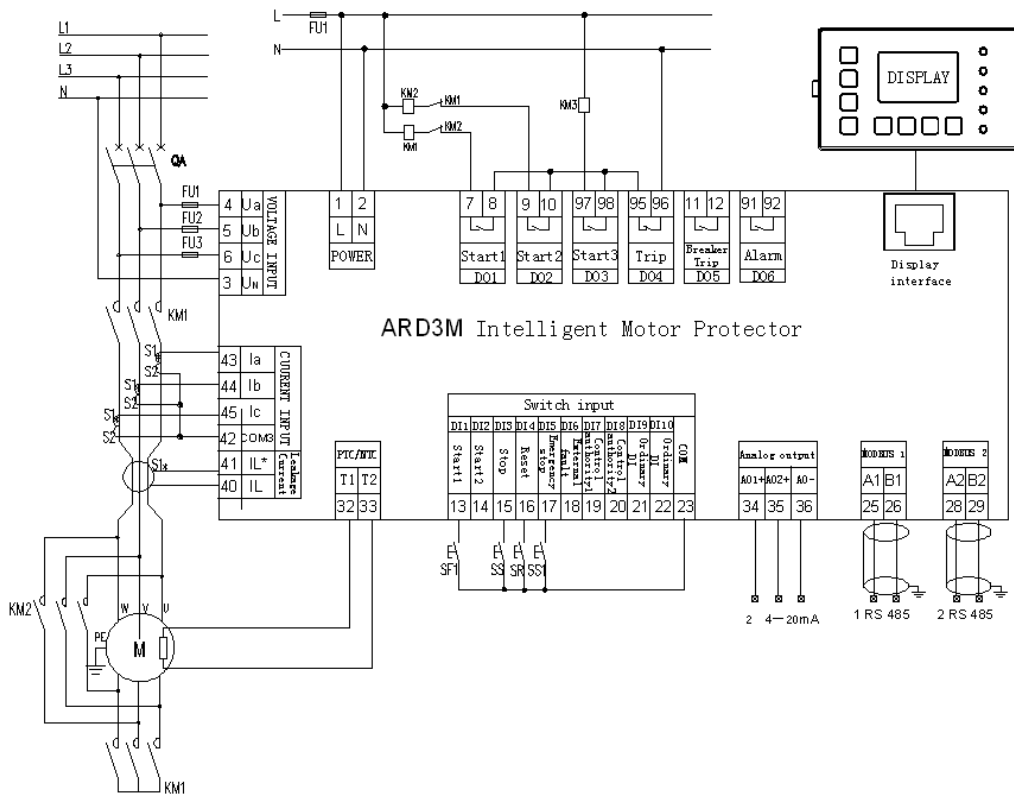

Y-△ start (three relay mode): motor start, stop is controlled by protector, Press the "Start 1" button on the display unit, Display unit control), DO1 relay (default start 1 function), DO5 relay (default start 3 function) closed, Close the KM1、KM3's main contacts, Motor Y starting, After the switch time DO1 the relay is disconnected, DO2 relay closed (default start 2 function), Close the KM2、KM3's main contacts, Motor into △ operation. Press the stop button on the panel, DO2 relay (default start 2 function), DO5 relay (default start 3 function) disconnected, KM1、KM2、KM3 coil is out of power, The motor stopped working.

Click switch input DI1(default start 1 function, Starting control is set to two-step mode, enabling local control), DO1 relay (default start 1 function), DO5 relay (default start 3 function) closed, Close the KM1、KM3's main contacts, Y motor starts, After the switch time DO1 the relay is disconnected, DO2 relay closed (default start 2 function), Close the KM2、KM3's main contacts, Motor into △ operation. Press the stop button, DO2 relay (default start 2 function), DO5 relay (default start 3 function) disconnected, KM1、KM2、KM3 coil is out of power, The motor stopped working.

9.6 ARD3M Electrical Motor Protector Double Speed Mode Connection

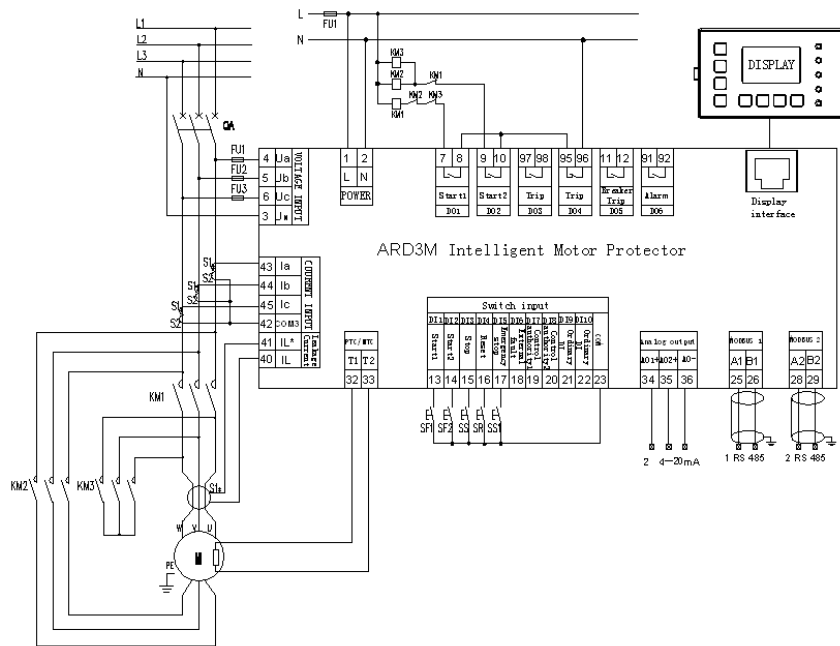

Double speed starting: motor starting and stopping are controlled by protector, Press the "Start 1" button on the display unit, Display unit control), DO1 relay (default start 1 function) closed, Close the KM1's main contacts, Motor starting at low speed; Press the start 2 button, DO1 relay (default start 1 function) disconnected, DO2 relay (default start 2 function) closed, Close the KM2、KM3's main contacts, Motor starting at high speed. Press the stop button on the panel, DO2 relay (default start 2 function) disconnected, KM2、KM3 coil is out of power, The motor stopped working.

Click switch input DI1(default start 1 function, Starting control is set to double speed mode, Local control), DO1 relay (default start 1 function) closed, Close the KM1's main contacts, Motor starting at low speed; Click switch input DI2(default start 2 function), DO1 relay (default start 1 function) disconnected, DO2 relay closed (default start 2 function), Close the KM2、KM3's main contacts, Motor starting at high speed. Click switch input DI3(default stop function), DO2 relay (default start 2 function) disconnected, KM2、KM3 coil is out of power, The motor stopped working.

10、 Features and Functions

10.1 Permissions programmable

Protector has perfect control authority programmable function, with permission for "two choose one" or "three choose one" use.

When the control permission is "two choose one ", the user can define the control permission output 1 and output 2: either of the display unit, communication in-place, remote and parking (both definitions are not repeatable).

For example, control permissions are defined as "two choose one ", control permission output type output 1 is defined as" communication control ", output 2 is defined as "remote control ". The DI7 is defined as control permission 1. When DI7(control permission 1) is disconnected, the control mode correspond to the control permission output 1 takes effect, and the control mode correspond to to the output 2 takes effect when the DI7(control permission 1) is connected. The

control permissions are selected as shown in Table 17 below:

Table 17

Control Permission Output Type	DI7 Control Permission Input 1 State
Output1——Communication control	0
Output2——Native control	1

When the control permissions are set to “three choose one”, The user can define control rights output 1, output 2, output 3, and output 4 as either of the display unit, communication in place, remote, and parking, respectively (each output definition is not repeatable), The effective output is selected by DI7(control permission 1), DI8(control permission 2) on-off. If control permission output 1 is defined as communication control, Output 2 is defined as "native" control, Output 3 is defined as "panel" control, Output 4 is defined as "remote" control, The control permissions are selected as shown in Table 18 below:

Table 18

Control permissions	DI Input state	
	DI7 Control permission 1	DI8 Control permission 2
Communication control	0	0
Native control	0	1
Panel control	1	0
Remote control	1	1

Note : "0" means switch input disconnected , "1" means turn on

10.2 Logic programmable

The protector has logic programmable function, and the user can program and define according to the required logic output function. Each logic function consists of five programmable input conditions A、 B、 C、 D、 E, freely combined by "with ", " or " relations. The programmable content of each input condition and the combination of input conditions can be seen in Table 11 menu.

Suppose the user needs to output passive signal when any fault occurs in blocking, short circuit, time limit overload, phase break, current imbalance, can set DO3(or other DO) to logic diagram output 1, set the condition of logic output 1 to $A*B*C*D*E$, and set the condition input A、 B、 C、 D、 E to block, short circuit, time limit overload, phase break, current imbalance fault, then block, short circuit, time limit overload, phase break, current imbalance fault any fault occurs, DO3—— logic diagram output 1 action, output passive signal.

Note : " + " representation and logic , " * " representation or logic.

10.3 Custom communication address

The protector has the function of customizing communication address, which makes communication reading more convenient and effective.

There are 120 communication addresses for user customization. Address 5000-5119 and 5300-5419, the correspond to data values can be customized. If the value of 5300 is written as 2010, the address 5000 is the same as the address 2010 data.

Example: Suppose the user needs to read and write the original address 2003,2300,2307,2309,2335,2357,2758,2800 frequently. These addresses are not continuous

addresses, each read an address data, need to send a MODBUS read command.

In this case, the efficiency can be improved by customizing the address function: the user can write the address 5300-5307 as 2003,2300,2307,2309,2335,2357,2758,2800 respectively, so that the definition of the address 5000-5007, read and write, value range and so on will correspond to the above address one by one. At this time, the user only needs to send a read command to achieve all data read and write.

11、 Examples of ordering

Example: specific model: ARD3M K1-100/H M1SR-60L1

Technical requirements: motor power 37 KW,1 4-20 mA analog output ,2-63 current, voltage harmonic measurement; with fault record

Communication protocol :2 channels RS485 protocol, MODBUS RTU protocol

Auxiliary power: AC 220V

Display mode :60 L1(black and white LCD)

Note: main body and transformer connection length 1m; main body and display unit connection length 1.5 m.

Jiangsu Acrel Electrical MFG Co.,Ltd.(Production Base)

Address : No31HongtuRd,NanzhaJiangyinJiangsu

Website: www.acrel.gr

Sales manager : Tim Ma

Tel/whatsapp/wechat : 8618761599716

E-mail : tim.ma@email.acrel.cn