

Multi-Circuit Metering

This is an integrated solution for monitoring multi-circuits and mains by using a single meter. The meter is designed for use in both new build and reconstruction and is used for critical power operations in data centres and energy management in buildings.

The ideal solution for data centre managers, energy or facility managers, engineers and operational executives who are responsible for delivering power to critical applications.

AMC16Z-FAK24 and AMC16Z-FAK48

- AMC16Z series AC branch circuit power meter can be used for building low-voltage distribution multi-circuit monitoring, especially for data center IT cabinet monitoring.
- It offers class 1 (1 %) power and energy system accuracy (including 50 A to 400 A CTs) on all branch circuits.
- AMC16Z-FAK24 monitor the full power parameters and switch state of 24 branches of double-channel AC outlet, 1-channel RS485 communication and phase adjustment.
- AMC16Z-FAK48 monitor the full power parameters and switch state of 48 branches of double-channel AC outlet, 1-channel RS485 communication and phase adjustment.
- AMC16Z-FAK24 and AMC16Z-FAK48 are commonly used in the Acrel AMC Precision Distribution Management System.

Solution

AMC16Z series meters are solutions for the following markets:

- Buildings
 - Data center
-

Benifits

- Flexible modules can be arbitrarily assembled to accommodate any PDU solution.
 - Support new construction and renovation projects. It has the advantage of flexible assembly to respond to special power distribution detection schemes.
-

Advantage

- Applicable to any PDU solutions scheme for new construction and renovation
 - Class 0.5 system accuracy
 - RS485 port
 - Small volume
 - Convenient installation
 - Flexible assembly
 - Construction convenient
-

Standards

- IEC61010-1
 - IEC62053-22 class 0.5
-

AMC16Z-ZA



1. 2DO
2. Standby current
3. Standby voltage
4. Main current
5. Main voltage
6. Communication & 24V DC power output
7. Leakage current
8. Temperature and humidity
9. 6-channel passive DI

Main Characteristics

High integration, used for monitoring main and standby circuit, 2-channel 3 phase AC inlet.

Output 24V to supply power to the outlet module, which can operate without extra power supply and relay.

IEC class 1 metering

V/A(mA)/ P/ Kwh class 0.5, Q/ Kvarh class 1.

Branch power and energy measurements fully meet ANSI and IEC class 1 accuracy requirements.

PQ: Basic power quality data is obtained by measuring the percentage of total harmonic distortion through voltage and current.

Design fits any PDU or RPP solution.

Support new construction and renovation projects.

Communicate with various systems: 1-channel RS485 prot, Modbus-RTU.

Compatible with AMC precision distribution management system.

It is easy to centrally collect equipment data and turn it into useful decision information.

AMC16Z-FAK24/AMC16Z-FAK48



1. Current detection
2. Voltage detection
3. Communication + auxiliary power DC24V

Main Characteristics

Used for monitoring the main and standby circuit AC outlet altogether 48 branches or 24 branches.

IEC class 1 metering

V/A(mA)/ P/ Kwh class 0.5, Q/ Kvarh class 1.

Branch power and energy measurements fully meet ANSI and IEC class 1 accuracy requirements.

PQ: Basic power quality data is obtained by measuring the percentage of total harmonic distortion through voltage and current.

Design fits any PDU or RPP solution.

Support new construction and renovation projects.

Communicate with various systems: 1-channel RS485 prot, Modbus-RTU .

Feature Selection	AMC16Z-ZA	AMC16Z-FAK24	AMC16Z-FAK48
Power and electrical energy measurement			
Main circuit	•		
Branch circuit 24		•	
Branch circuit 48			•
Instantaneous acquisition value			
Voltage	•	•	•
Current	•	•	•
Active power	•	•	•
Reactive power	•	•	•
Power factor	•	•	•
Zero ground voltage	•		
Neutral current	•		
Leakage current	•		
Environment temperature	•		
Environmental humidity	•		
6 passive switching inputs	•		
Electric power data			
Frequency	•	•	•
Active energy	•	•	•
Reactive energy	•	•	•
Power quality measurement			
Total harmonic distortion (THD), 2-63rd harmonics, current and voltage unbalance	•		
Total harmonic distortion (THD), 2-31rd		•	•
Sampling rate points per cycle: 8000 Hz	•	•	•
Auxiliary supply			
AC 220V	•		
DC 12~24V		•	•
Communication			
RS-485 prot	•	•	•
Modbus RTU	•	•	•



Matched Solid Type Current Transformer

Model	Ratio	Hole Size (mm)	Accuracy	Picture
AKH-0.66W-9N	50A/50mA	φ9	Class 0.2	
AKH-0.66W-12N	100/50mA	φ12	Class 0.2	
AKH-0.66W-20	200/50mA	φ20	Class 0.5~ 0.2	
AKH-0.66W-30N	400/50mA	31*13	Class 0.5~ 0.2	
AKH-0.66W-7	5-40A/20mA	φ7	Class 0.5~ 0.2	
AKH-0.66W-8	5-60A/20mA	φ8	Class 0.5~0.2	
AKH-0.66W-12	5-100A/20mA	φ12	Class 0.5~ 0.2	
AKH-0.66/EMS	50A/10mA	/	Class 0.2	

Matched Split Core Current Transformer

Model	Ratio	Hole Size (mm)	Accuracy	Picture
AKH-0.66K-φ10	40-50A/20mA	φ10	Class 0.5	
AKH-0.66K-φ16	40-100A/20mA	φ16	Class 0.5	
AKH-0.66K-φ24	60-200A/20mA	φ24	Class 0.5	
AKH-0.66K-φ36	400A/50mA/200-400A/20mA	φ36	Class 0.5	

External Dimension Drawing of Transformer

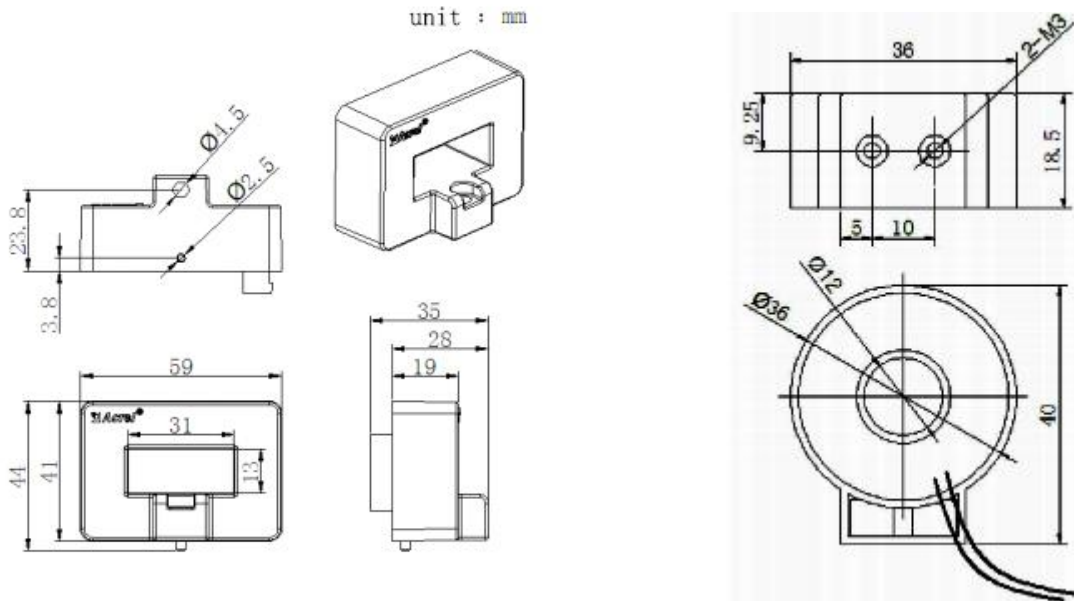

Specifications	Rated current ratio	Accurate level and corresponding rated load (Ω)			Go through turns	Bus spec. (mm)/ pieces
		Class 0.2	Class 0.5	Class 1		
W-9N	50A/50mA	10			1	Φ12
W-12N	100A/50mA	10			1	Φ12
AKH-0.66/W-2 0N	(500-100)A/ 50mA		10		1	20×10/1
W-30	(100-200) A/20mA	10			1	30×10/1

Technical Parameters

AMC16Z-ZA		
Measured parameters		Voltage, current, frequency, active power, reactive power, power factor, active energy, reactive energy.
		Voltage, current, frequency, active power, reactive power, power factor, active energy, reactive energy.
Periodic sampling frequency		
Bus voltage	Rated	Overload 220V AC
	Measuring range	±20%
	Overload	Instantaneous voltage 2 times/s
Current inlet circuit	Rated	5A Secondary 5 A
	Range	0~6A
	Coverload	The duration is 1.2 times and the instantaneous duration is 10 times/s
Temperature and humidity	Temperature range	-40℃ ~ +99℃
	Humidity range	20% ~ 90%
Input frequency		45 ~ 60Hz
Measurement accuracy	Inlet line	Voltage/current class 0.2, active power/power class 0.5, reactive power/power class 1
	Temperature	±1℃
	Humidity	±5%
Auxiliary supply		Signal power take-up (≤15W)
Environment	Temperature	Working: -15℃ ~ 55℃ Storage: -25℃ ~ 70℃
	Humidity	Relative humidity ≤93%
	Altitude	≤2500m
Switching output		2-channel 3A 250VAC/3A 30VDC
Switching input		6-channel dry contact
Communication		RS485/Modbus-RTU
Installation		DIN35mm guide rail or bottom plate mounting
Protection grade		IP20
Pollution levels		2
Mechanical properties	Space Take-up	94.3mmW*180mmL*45mmD

AMC16Z-FAK24/AMC16Z-FAK48		
Measured parameters		Voltage, current, frequency, active power, reactive power, power factor, active energy, reactive energy, switching state.
		2-31st harmonics
Bus voltage	Rated	220VAC
	Measuring range	±20%
	Overload	Instantaneous voltage 2 times/s
Outgoing current circuit	Rated	50mA
	Range	0.125~60mA
	Overload	Duration is 1.2 times and the instantaneous is 10
Input frequency		45~60Hz
Measuring Accuracy	Outlet line	Voltage/current/active power/act
Auxiliary power		Power supply by AMC16Z-ZA
Environment	Temperature	Working: -15°C ~ 55°C Storage: -25°C ~ 70°C
Humidity		Relative humidity ≤93%
Altitude		≤2500m
Communication		RS485/Modbus-RTU
Installation		DIN35mm guide rail or bottom plate mounting
Protection grade		IP20
Pollution levels		2
Mechanical properties	Space Take-up	94.3mmW*180mmL*45mmD

Note:

The rated input current of the secondary side of AMC16Z-FAK module is 50mA, and the default value of the primary side current is 50A. If the current transformer is different, customers can set the ratio by touch screen or upper computer according to the actual use situation.

Outline Shape

AMC16Z series AC precision power distribution monitoring device

Unit: mm

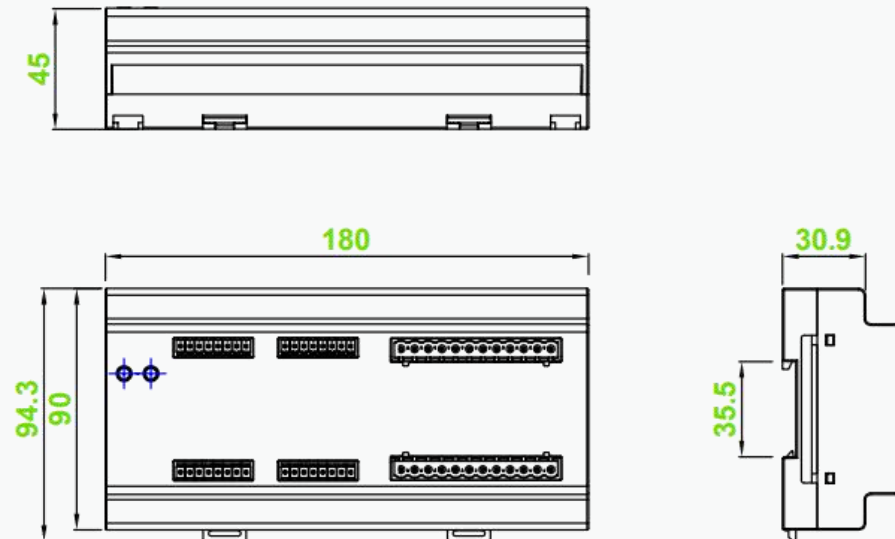
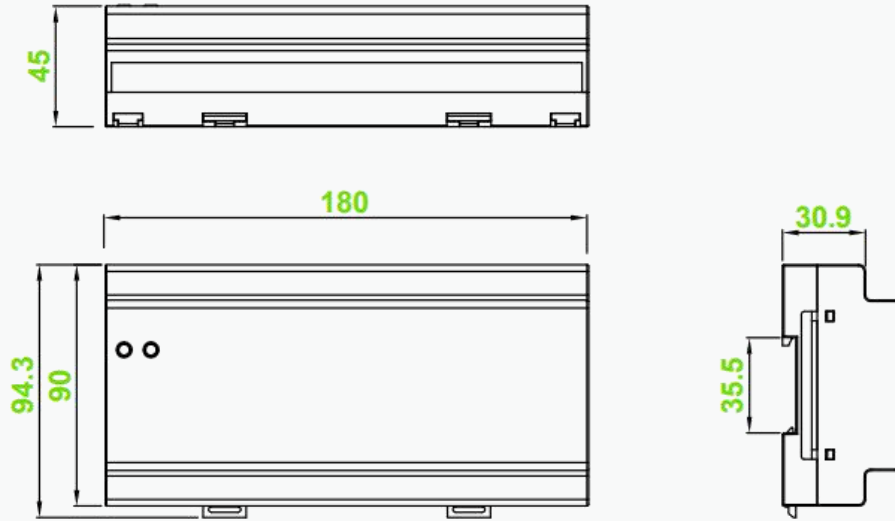

Note: There are outlet terminals on the AMC16Z-FAK48 housing. A space of at least 30mm should be left above the housing.

Installation Diagram

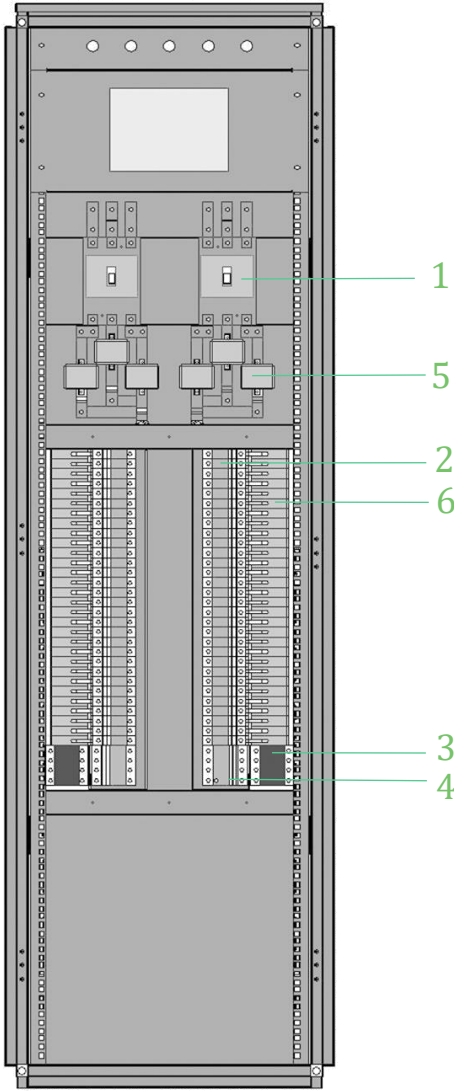

Top view(A)

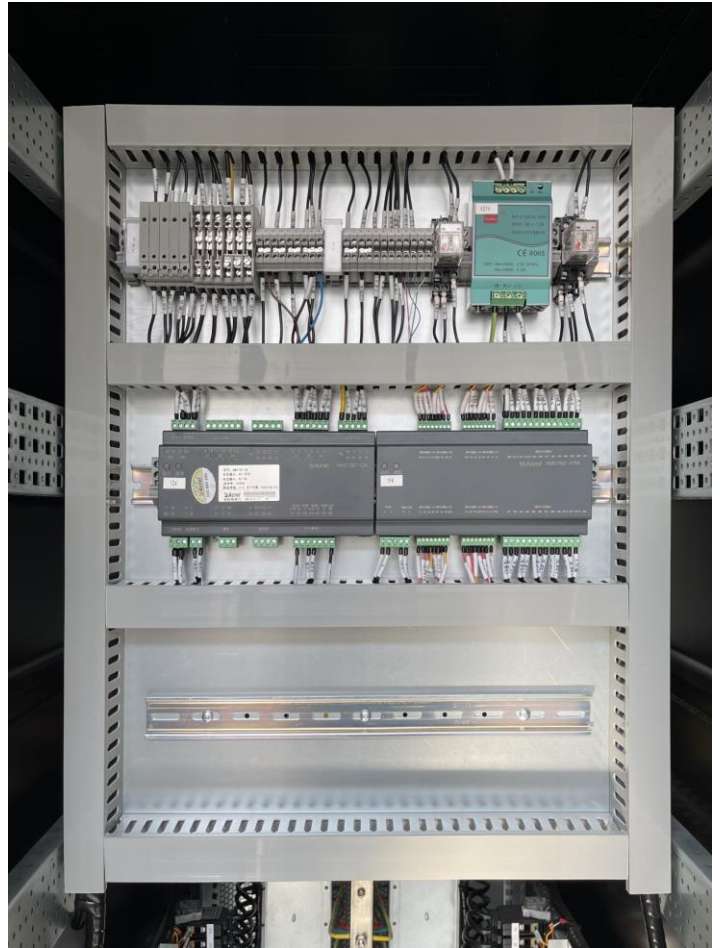

(B)

Picture A				
NO.	Instructions	Product	Model	QTY
6	1CT1-30、2CT1-30	CT	AKH-0.66 EMS 50A/50mA	60
5	1CT-6CT	CT	AKII-0.66 G-30T 250A/5A	6
4	1SPD、2SPD	SPD	ARU2-40/385/4P-S	2
3	1QF31、2QF31	QF	IC65N 4P C32A	2
2	1QF1-30、2QF1-30	QF	TC65N IP C32A	60
1	1QF0、2QF0	QF	NSX250N 3P3D 250A	2