

Sales manager : Tim Ma
Tel/whatsapp/wechat : 86 18761599716
E-mail : tim.ma@email.acrel.cn
Website: www.acrel.gr



Medical IT System Insulation Monitoring Devices (4-Piece Set)

Installation and Operation Manual V2.7

Acrel Co., Ltd.

Declaration

Please read this instruction carefully before using this product. All pictures, logos and symbols involved are owned by Acrel Co., Ltd. All or part of the content shall not be reproduced publicly without written authorization by non-company personnel.

Please read the instructions and precautions in this operation manual carefully before using this series of products. Acrel will not be responsible for personal injury or economic loss caused by ignoring the instructions in this operation manual.

The equipment is professional electrical equipment, any related operation, need to be carried out by special electrical technicians. Acrel is not responsible for personal injury or financial loss resulting from the error of non-professional personnel.

The contents of this description will be updated and amended constantly, and it is inevitable that there will be a slight discrepancy between the physical product and the description in the product function upgrading. Please refer to the physical product purchased and obtain the latest version of the description through [www. acrel.cn](http://www.acrel.cn) or sales channels.

Modified Records

No.	Time	Versions	Reasons for revision
01	2016.01.20	V2.0	On the basis of the original insulation monitoring products, the contents of all five pieces of products are integrated to replace the instructions of each sub-product.
02	2016.10.25	V2.1	Some errors have been fixed
03	2016.11.07	V2.2	The overview added "products conform to Enterprise standards Q31/0114000129C013-2016 <i>IT System Insulation Monitoring Instrument</i> "
04	2020.04.29	V2.3	Delete some discontinued accessories; Add the installation dimension of AID10 cabinet door
05	2020.06.11	V2.4	Add AID150 cabinet door installation diagram
06	2020.08.14	V2.5	Correct errors and omissions, adjust the wording
07	2021.01.20	V2.6	update version
08	2022.02.18	V2.7	Revise mistakes and omissions, update product pictures, update typical cases, update catalogue, update current transformer content
Note:			

Contents

1 Introduction	1
2 Function features	2
2.1 Function features of AITR series medical isolation transformer	2
2.2 AIM-M10 medical intelligent insulation monitor	2
2.3 Function features of AID10/150	2
2.4 Function features of AKH-0.66P26 current transformer	3
3 Reference standard	3
4 Technical parameters	3
4.1 Technical parameters of AITR series medical isolation transformer	3
4.2 Technical parameters of AIM-M10 medical insulation monitor	4
4.3 Technical parameters of AID10/AID150	5
4.4 Technical parameters of AKH-0.66P26 current transformer	5
5 Installation and wiring	6
5.1 Shape and mounting hole size	6
5.2 Installation method	7
5.3 Wiring method	10
5.4 Typical wiring diagram	12
5.5 Considerations	13
6 Programming and application	14
6.1 Panel description	14
6.2 LED indicator instructions	15
6.3 Button function descriptions	15
6.4 Button operation descriptions	16
7 Communication protocol	20
7.1 Modbus-RTU communication protocol	20
7.2 Introduction to the function code	20
7.3 AIM-M10 parameter address table	21
8 Typical applications	23
9 Power on and debugging instructions	23
9.1 Wiring check	23
9.2 Common faults and eliminations	24
9.3 Settings and debugging	25



Medical IT System Insulation Monitoring Devices



1 Introduction

Medical IT systems are primarily used in critical medical 2 locations such as operating rooms, ICU/CCU intensive care units to provide safe, reliable, and continuous distribution of critical equipment in these locations. Medical insulation monitoring products are developed by Acrel according to the special requirements of insulation resistance of distribution system in medical 2 type places with many years of design experience in the power meter industry. It can be used for isolating power system in various operating rooms and intensive care units in medical places, realizing real-time monitoring of system insulation, load, isolation transformer temperature and other operating conditions, as well as remote monitoring. Products comply with the enterprise standard Q31/0114000129C013-2016 *IT System Insulation Monitor* provisions.

Insulation monitoring products of medical IT system (4-piece set) include AITR series medical isolation transformer, AIM-M10 medical intelligent insulation monitor, AKH-0.66P26 current transformer and AID series (AID10, AID150) external alarm and display instrument, etc., as shown in Table 1.

Table 1 Medical IT System Insulation Monitoring Products

Type	Picture	Description
AITR series medical isolation transformer		AITR series isolation transformer is specially used in medical IT system. The windings are treated with double insulation and have electrostatic shielding layer, which reduces electromagnetic interference between windings. The PT100 temperature sensor is installed in the wire bag to monitor the temperature of transformer. The whole body is treated with vacuum invasion paint, which increases mechanical strength and corrosion resistance. The product has good temperature rise performance and very low noise.
AIM-M10 medical intelligent insulation monitor		The AIM-M10 medical intelligent insulation monitor is compact in size, easy to install, intelligent, digital and networked, and is an ideal choice for insulation monitoring of isolation power supply systems in operating rooms, intensive care units and other medical places.
AKH-0.66P26 current transformer		The AKH-0.66P26 type current transformer is the protective current transformer supporting the AIM-M10 insulation monitor, of which the maximum measurable current is 60A and the transformation ratio is 2000:1. The current transformer is directly fixed inside cabinet by screwing, and the secondary side is led out by the terminal, which is convenient to install and use.

AID series external alarm and display instrument	AID10		It is suitable for wall installation embedded in operating room or nurse station and can monitor 1 AIM-M10 insulation monitor. It has sound and light alarm function of insulation, overload, overtemperature and equipment failure, and RS485 communication
	AID150		LCD display, RS485 bus, centralized monitoring of up to 16 SETS of AIM-M10 medical intelligent insulation monitor data, sound and light alarm can be remote. The AID150 can also monitor data from multiple AIM-R100 residual current monitors.

2 Function features

2.1 Function features of AITR series medical isolation transformer

- The transformation ratio between the primary and secondary windings is 1:1;
- Double insulation treatment is adopted between the windings, and the electrostatic shielding layer is designed;
- The Pt100 temperature sensor is installed in each wire packet to monitor the temperature of the isolation transformer;
- Used for the transformation of TN system into IT system (ungrounded system) after isolation transformer.

2.2 AIM-M10 medical intelligent insulation monitor

- Real time monitoring of IT system to ground insulation resistance, transformer load current, transformer winding temperature, and give alarm indication when fault occurs;
- The real-time monitoring system wire break fault, temperature sensor wire break fault and function ground wire break fault, and give alarm indication when the fault occurs;
- Relay output, LED indicator and other fault indication;
- Modbus, which communicates with external alarm and display instrument, can monitor the operation of IT system remotely;
- Event record, including the time and type of the alarm, is convenient for the operator to analyze the operation status of the system and eliminate the fault in time;
- DC24V power output function can provide power for external alarm and display instrument.

2.3 Function features of AID10/150

- The insulation resistance alarm value, load current alarm value and transformer temperature alarm value of the system can be set remotely;
- When the system appears insulation fault, overload, transformer temperature over limit and wiring fault, alarm and display instrument gives out the corresponding sound and light alarm, and has the function of eliminating sound alarm;
- Using advanced fieldbus technology, the remote monitoring function can be realized by real-time

data interaction with the insulation monitor.

Table 2 Functional Description of AID Series Products

Model	Selection Description
AID10	It can monitor one set of AIM-M10 insulation monitor and be used for installation by embedding into wall.
AID150	It can monitor 16 sets of AIM-M10 insulation monitoring instruments to the maximum and AIM-R100 residual current monitor which can be used for installation by embedding into wall. It is fit for the centralized monitoring on operating room or ICU or other sites.

2.4 Function features of AKH-0.66P26 current transformer

- The maximum measurable current is 60A, and the transformation change ratio is 2000:1;
- Work with the AIM-M10 insulation monitoring instrument to measure the load current of isolation transformer.

3 Reference standard

- ◆ IEC 60364-7-710 *Building electrical installations section 7-710: Requirements for special installations or locations----medical locations;*
- ◆ IEC 61557-8 *Electrical safety of low voltage distribution system below AC 1000V and DC 1500V, Test, measurement or monitoring equipment for protection test section 8: Insulation monitoring device for IT systems;*
- ◆ IEC 61557-9 *Electrical safety of low voltage distribution system below AC 1000V and DC 1500V, Test, measurement or monitoring equipment for protection test section 9: insulation fault positioning equipment for IT systems;*
- ◆ IEC61558-1 *Safety of power transformers, power supplies, reactors and similar products section 1: General requirements and tests;*
- ◆ IEC61558-2-15 *Safety of power transformers, power supplies and similar products section 16: Special requirements for isolation transformers for power supply in medical locations.*

4 Technical parameters

4.1 Technical parameters of AITR series medical isolation transformer

Refer to Table 3.

Table 3 Technical Parameters of AITR Series of Medical Isolation Transformer

Type	AITR10000	AITR8000	AITR6300	AITR5000	AITR3150
Insulation class	H	H	H	H	H
Protection class	IP00	IP00	IP00	IP00	IP00
Power/voltage/ current					
Rated power	10000VA	8000VA	6300VA	5000VA	3150VA
Rated frequency	50/60Hz	50/60Hz	50/60Hz	50/60Hz	50/60Hz
Rated input voltage	AC230V	AC230V	AC230V	AC230V	AC230V
Rated input current	45.3A	36A	28.5A	22.5	14.2A

Rated output voltage	AC230V/115V	AC230V/115V	AC230V/115V	AC230V/115V	AC230V/115V
Rated output current	43.5A	34.7A	27.4A	21.7	13.7A
Inrush current	<12In	<12In	<12In	<12In	<12In
Leakage current	<200 μ A	<200 μ A	<200 μ A	<200 μ A	<200 μ A
No load input current	1.359A	1.08A	0.855A	0.675A	0.426A
No load output voltage	235V \pm 3%	235V \pm 3%	235V \pm 3%	235V \pm 3%	235V \pm 3%
Short circuit voltage	<6.9V	<6.9V	<6.9V	<6.9V	<7.5V
General parameters					
Fuse wire	80A	63A	50A	35A	25A
Primary winding resistance	<55m Ω	<64m Ω	<80m Ω	<131 m Ω	<245m Ω
Secondary winding resistance	<45m Ω	<64m Ω	<80m Ω	<116 m Ω	<228m Ω
Iron loss	<150W	<105W	<107W	<77W	<55W
Copper loss	<230W	<200W	<170W	<125W	<120W
Efficiency	>96%	>96%	>96%	>96%	>95%
Maximum ambient temperature	<40 $^{\circ}$ C	<40 $^{\circ}$ C	<40 $^{\circ}$ C	<40 $^{\circ}$ C	<40 $^{\circ}$ C
No-load temperature rise	<36 $^{\circ}$ C	<33 $^{\circ}$ C	<31 $^{\circ}$ C	<26 $^{\circ}$ C	<22 $^{\circ}$ C
Full load temperature rise	<65 $^{\circ}$ C	<76 $^{\circ}$ C	<67 $^{\circ}$ C	<62 $^{\circ}$ C	<55 $^{\circ}$ C
Noise grade	<40dB	<40dB	<40dB	<40dB	<40dB

4.2 Technical parameters of AIM-M10 medical insulation monitor

Refer to Table 4.

Table 4 Technical parameters of AIM-M10 insulation monitoring instrument

Auxiliary power supply	Voltage	AC220V (\pm 10%)	Temperature measurement	Thermistor	Pt100
	Frequency	50/60Hz		Measuring range	-50~+200 $^{\circ}$ C
	Power consumption	<5W		Alarm value range	0~+200 $^{\circ}$ C
Insulation monitoring	Measuring range of insulation resistance	10~999k Ω	Alarm output	Output mode	1 relay output
	Absolute percentage error	0 \pm 10%		Contact capacity	AC 250V/3A DC 30V/3A
	Alarm value	50~999k Ω	Environment	Operating temperature	-10~+55 $^{\circ}$ C
	Response time	<2s		Storage temperature	-20~+70 $^{\circ}$ C

	Measuring voltage	<12V		Relative humidity	5~95%, non-condensate
	Measuring current	<42 μ A		Altitude	\leq 2500m
Load current	Measuring range	2.1~50A	Communication		RS485, Modbus-RTU
	Alarm value	5~50A	Rated impulse voltage/pollution degree		4KV/III
	Measuring accuracy	\leq ±5%	EMC/EMR		Conform to IEC 61326-2-4

4.3 Technical parameters of AID10/AID150

Refer to Table 5.

Table 5 Technical parameters of AID10/150

Parameter		Type	AID10	AID150
Auxiliary power supply	Voltage		DC 24V	
	Consumption		< 0.6W	
Insulation alarming range			—	14A, 18A, 22A, 28A, 35A, 45A
Temperature alarm setting range			—	0~+200°C
Number of monitored systems			1	16
Alarm method			Sound-light alarm	
Alarm type			Insulation failure, overload, overheat, equipment failure	
Communication mode			RS485, Modbus-RTU	
Display mode			LED display	128×64 LCD display

4.4 Technical parameters of AKH-0.66P26 current transformer

Refer to Table 6.

Table 6 Technical Parameters of AKH-0.66P26 Current Transformer

Input current	0.5mA~50A	Frequency range	0.02~10 kHz
Output current	0.025~25 mA	Loading resistance	<200 Ω
Temperature coefficient	100 ppm/°C	Transient current (1s)	200A
Phase displacement	10'	Installation	Fixed with 4×10 screws
Operating temperature	-35~+70°C	Secondary wiring	Shielded twisted pair cable 2*0.3mm ² , 2m
Storage temperature	-40~+75°C		
Secondary resistance range	95~120 Ω	Isolation pressure	5000Vac
Accuracy	0.5%	Linearity	0.5%

5 Installation and wiring

5.1 Shape and mounting hole size

5.1.1 External dimensions of AITR series medical isolation transformer (unit: mm)

Shape and size of AITR series medical isolation transformer are shown as below and in Table 7.

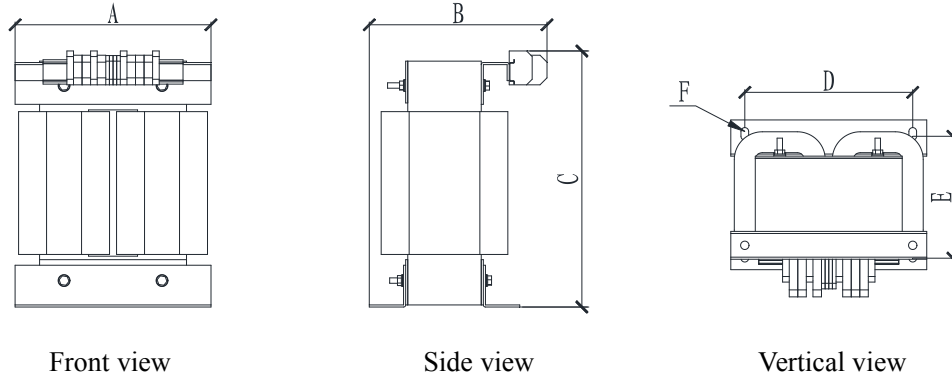
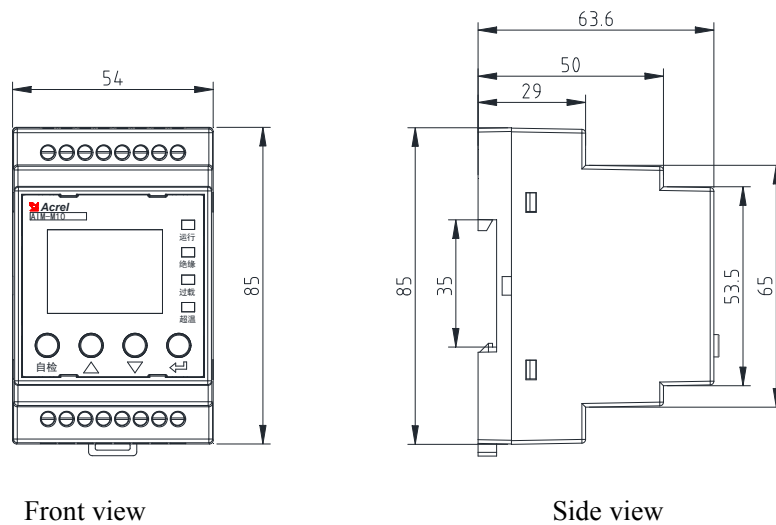

Table 7 External Dimensions of AITR Series Medical Isolation Transformer

Type	Capacity	A(mm)	B(mm)	C(mm)	D(mm)	E(mm)	F(mm)	Total weight
AITR10000	10000	280	240	427	240	190	11*8	92
AITR8000	8000	280	240	427	240	190	11*8	90
AITR6300	6300	280	225	427	240	175	11*8	75
AITR5000	5000	280	225	427	240	175	11*8	73
AITR3150	3150	280	215	427	240	175	11*8	53

Note: according to the standard, the maximum capacity of medical single-phase isolation transformer is 10kVA; Dimensions A, B, and C are the length, width, and height of the transformer; dimensions D, E, and F are the installation dimensions of the transformer; F is the mounting hole position. M8*30 screws are recommended to fix the transformer.

5.1.2 External dimensions of AIM-M10 medical insulation monitor (unit: mm)



5.1.3 External dimensions of AID series (unit: mm)

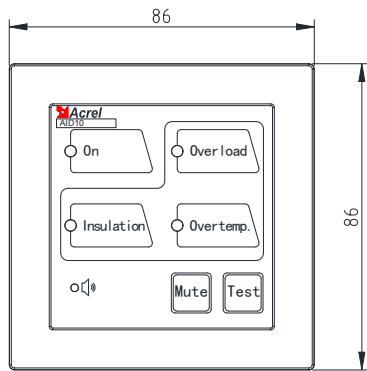

AID10 front view

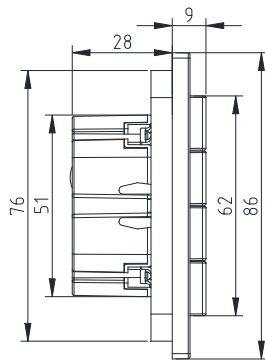

AID10 side view

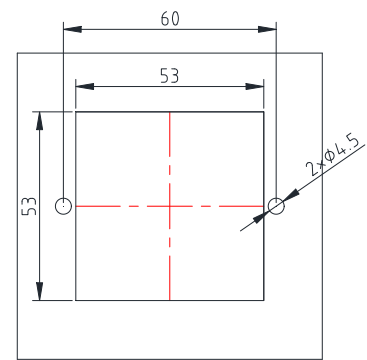

AID10 hole size

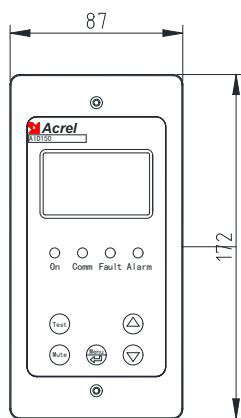

AID150 Front view

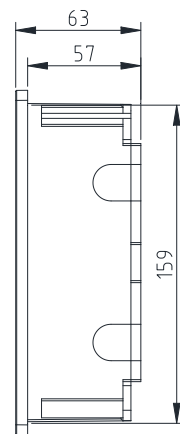

AID150 Side view

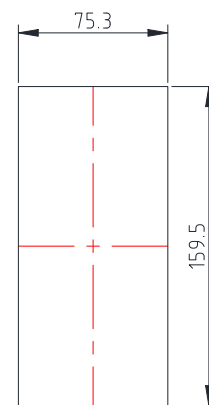

AID150 Hole size

5.1.5 External dimensions of AKH-0.66P26 current transformer (unit: mm)

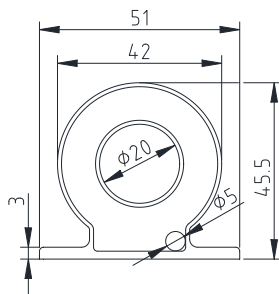

Front view

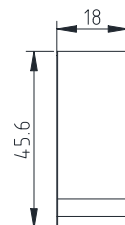

Side view

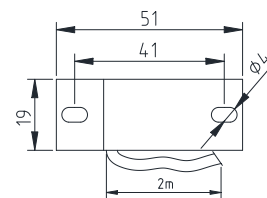

Bottom view

5.2 Installation method

In addition to the AID series external alarm and display instrument, the five-piece insulation monitoring products of medical IT system should be centrally installed in the distribution cabinet (isolated power cabinet). The isolation transformer should be installed at the bottom of the distribution cabinet, fixed with supporting bolts, and cooling fan should be installed. The instrument and circuit breaker are mounted on the upper panel. If the isolation transformer is installed separately, it should not be too far from the AIM-M10 insulation monitor. When the AID10/150 external alarm and display instrument is used in the operating room, it can be embedded in the wall and installed next to the information panel in the operating room for the convenience of manual medical personnel. When AID150 is used in ICU/CCU and other intensive care units, it should be installed in the hand nurse

station for the nurses on duty to check, and the RS485 communication between each insulation monitoring instrument, AID centralized alarm and display instrument under centralized monitoring should be connected hand in hand. The external wiring of the AID series external display device includes two 24V power lines and one RS485 communication line with 2-core shielded twisted pair. These three lines are drawn from the isolated power cabinet, and pipelines should be reserved during construction.

5.2.1 Installation mode of AIM-M10 medical insulation monitor

AIM-M10 insulation monitor adopts the installation method of the guide rail, and the fixation mode is the clip buckle type, as shown in the following figure:

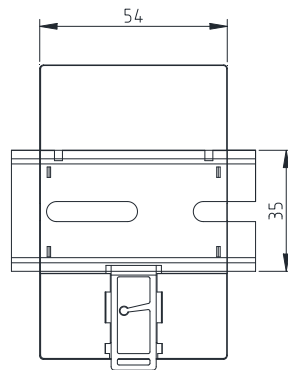

5.2.2 Installation mode of AID series alarm and display instrument

(1) If AID10 is embedded into the wall, the standard 86*86 mounting hole shall be reserved. The installation diagram is as follows:

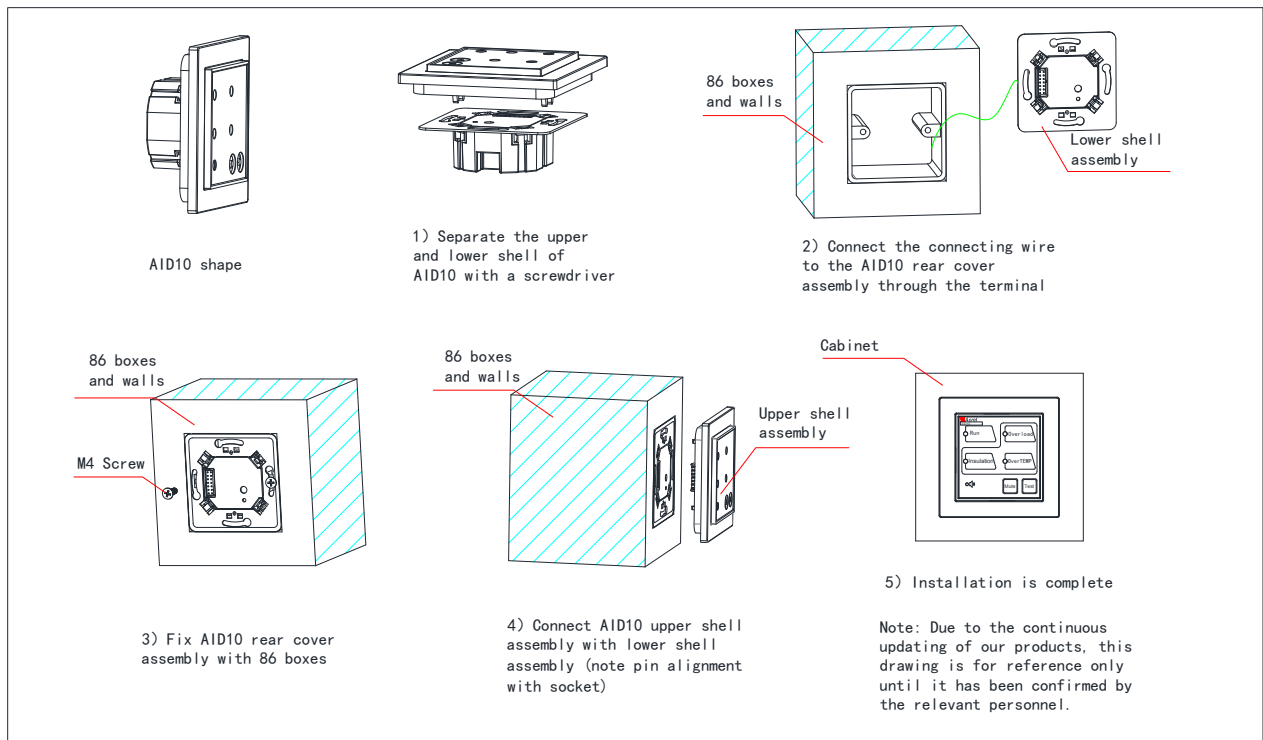

When decorating, first place in the right wall openings, and then isolated power cabinet lead (2 power cable with 1.5mm² cables and 1 shielded twisted-pair cable with 1.5mm² cable) introducing the

receiving terminal, the shell knocked down hole near the line, then embedding external alarm and display the shell wall and internal fixation, the terminal to circuit board corresponding terminals on the front cover, Install the panel on the housing and fix it with the supplied tapping screws.

(2) If AID10 is installed by opening the cabinet door, the installation diagram is as follows:

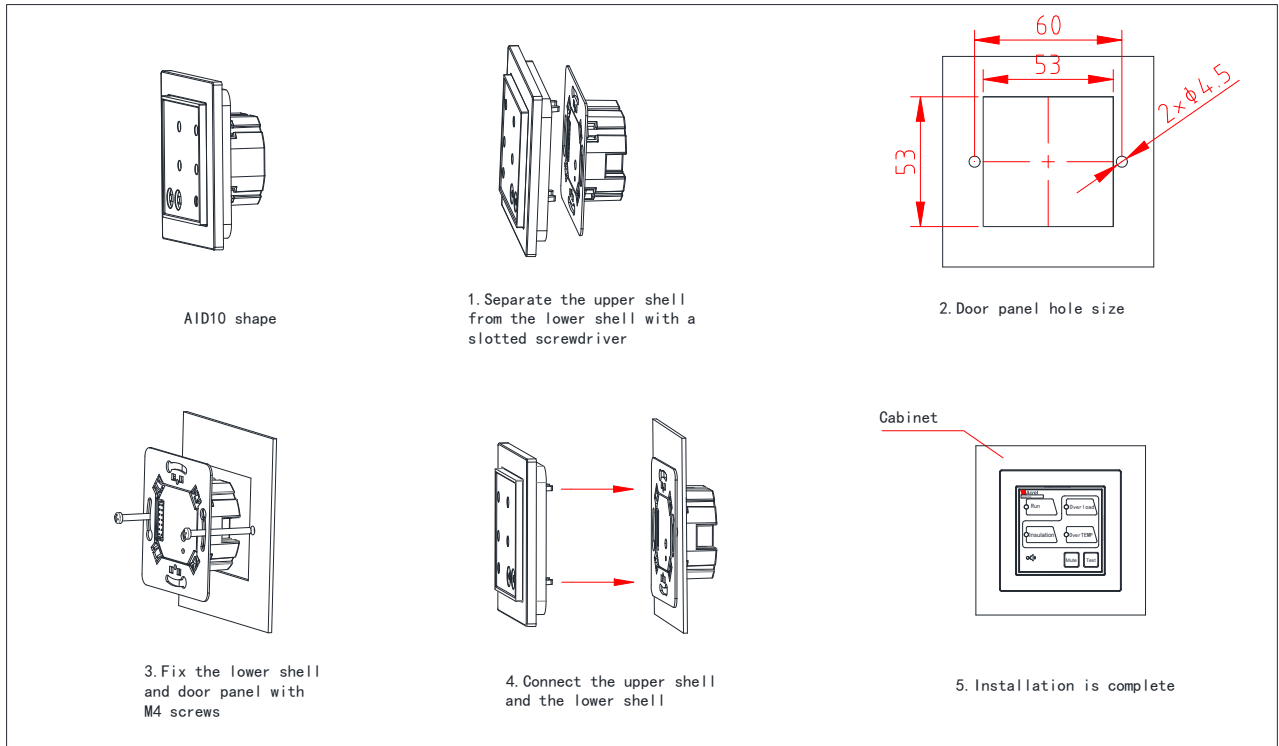

5.2.3 Installation mode of AID150

(1) If you choose to embed the wall for installation, the installation diagram is as follows:

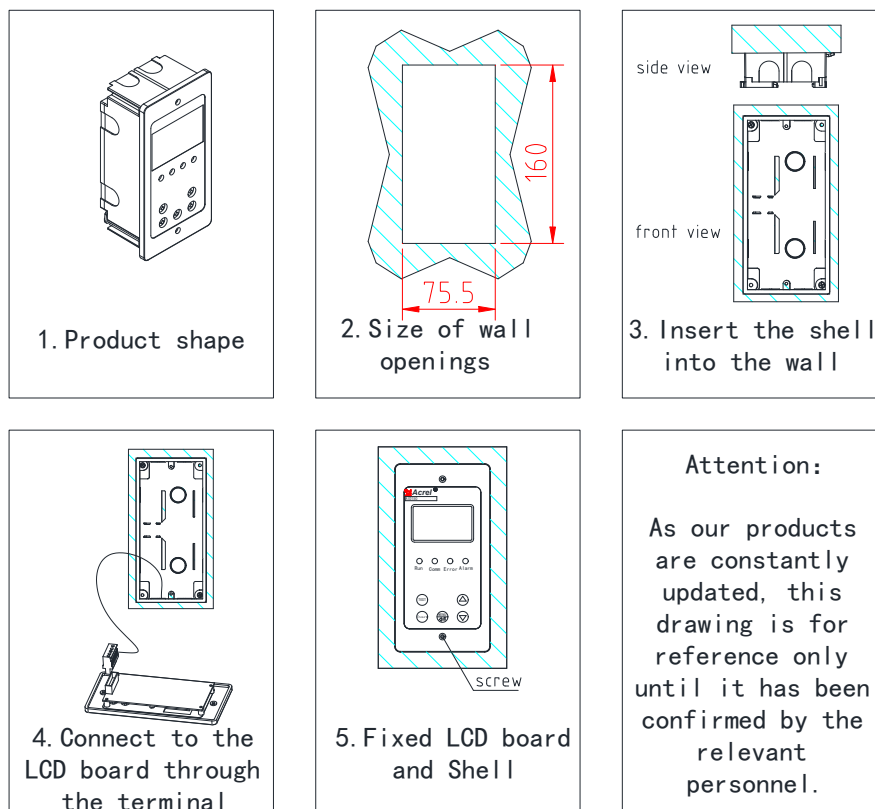

(2) If the AID150 external alarm and display instrument is installed by opening the cabinet door, the installation diagram is as follows:

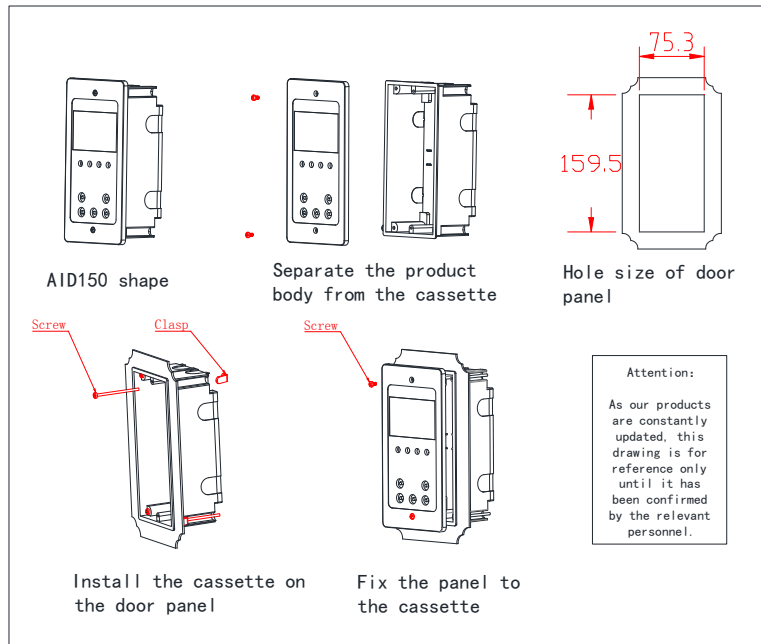

5.3 Wiring method

5.3.1 Wiring mode of AITR series medical isolation transformer

The input terminals at the transformer terminal blocks are labeled with "PM", in which two terminals 0 and 230 are connected to the input 220V single-phase AC. The output terminals are labeled with "SEC", in which the output voltage of two terminals 0 and 230 is AC 220V and is connected to external field load. The S terminal is connected to the PE bus bar on the spot (or the equipotential terminal line). Two ST terminals are temperature sensor interfaces, which are respectively connected to the 17 and 18 terminals of AIM-M10 insulation monitoring instrument.

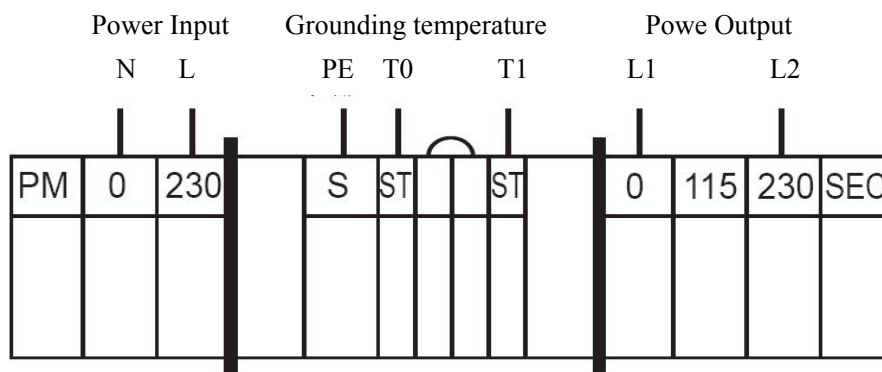

Note: The wirings of input and output terminals of the isolation transformer should select the copper wires matching the line diameter based on the isolation transformer rated input and output current (refer to tables in section 5.4). S terminal wiring can select 2×4mm² yellow-green wire. The wiring of two ST terminals can select 2×1.5mm² shielded twisted pairs, and the wiring should not be too long.

5.3.2 Wiring mode of AIM-M10

Lower row terminals: FE, KE (1,2) are connected to the field equipotential grounding terminal block

as instrument functional grounding. A, B (3,4) are communication terminals connected with external alarm and display instrument.+24V, 0V (5,6) are DC power output to supply power for alarm and display instrument. J (7,8) are output of over temperature alarm relay (used to control cooling fan).

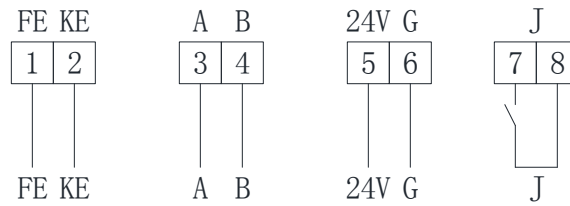

Grounding Communication 24V output relay output

Upper terminal: L1, L2 (11, 12) are connected with monitored IT system. I0, I1 (15, 16) are signal input of current transformer AKH-0.66P26. T0, T1 (17, 18) are signal input of temperature sensor.

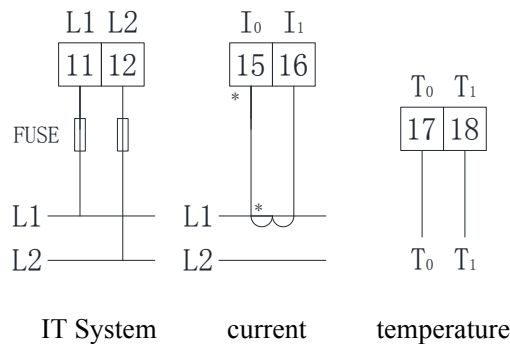

IT System current temperature

Note:

(1) The wirings connecting the 11 and 12 terminals of the insulation monitor can select 2×1.5mm² copper wires, and the FE and KE terminals corresponding to the 1 and 2 can select 2×4mm² yellow-green wires (grounding wires). relay output are the dry nodes, which need additional power supply during the control of external load. For example, J1 controls AC 220V cooling fan, then the AC 220V power supply is needed, and the wiring line type should be determined according to the load current.

(2) 2×1.5mm² shielded twisted pair cable can be selected for current transformer signal line corresponding to terminals 15 and 16, temperature signal line corresponding to terminals 17 and 18, RS485 communication line corresponding to terminals 3 and 4. The COM port for communication does not need wiring.

5.2.3 Wiring mode of AID10/150 centralized alarm and display instrument

The terminals of the power supply correspond to the positive pole and ground of the 24V DC power module respectively. A and B are connected with A and B in the lower terminal of AIM-M10.

The wiring diagram is shown in the following figure.

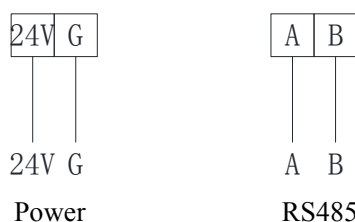

The 24V power supply can be connected by multiple copper wires of 2 x 1.5mm², and the RS485

communication terminal can be connected by shielded twisted pair of 2 x 1.5mm².

5.4 Typical wiring diagram

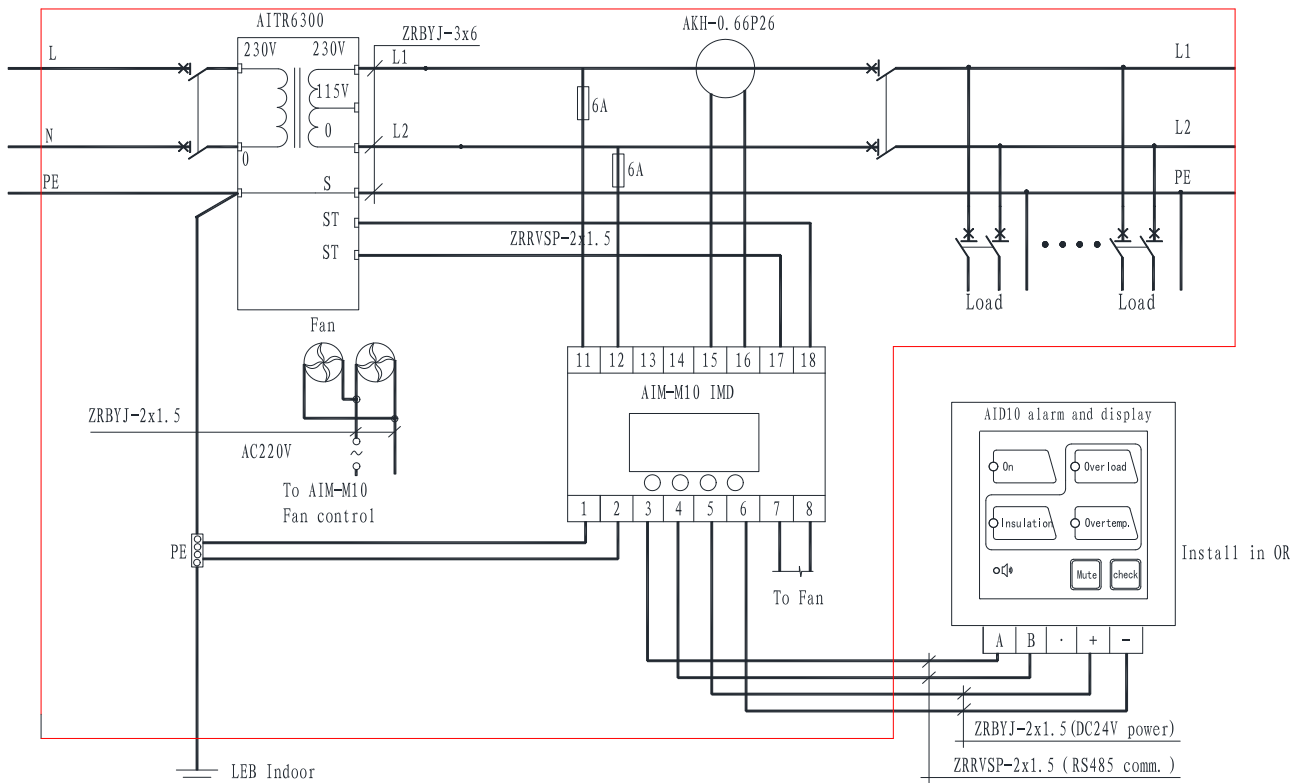

More information:

(1) The connection line diameter of the input and output of the isolation transformer should match the rated current of the isolation transformer, or it can be selected according to the following table:

Isolation transformer type	Selected line diameter
AITR3150	3×4mm ²
AITR5000/AITR6300	3×6mm ²
AITR8000/AITR10000	3×10mm ²

(2) Terminals 11 and 12 of AIM-M10 insulation monitor need to be connected with AC220V of IT system, which can be directly connected to 0 and 230V output terminals at the secondary side of isolation transformer according to the diagram, and connected with 6A fuse protection in series.

(3) The relay output control of the 7 and 8 terminals of the AIM-M10 insulation monitor is a dry node, which needs an additional fan power supply when used for the fan control. When multiple transformers are centrally installed in one isolation power cabinet, multiple fans should be connected in a parallel mode controlled by multiple insulation monitors, that is, every one insulation monitor can start or stop all fans.

(4) AKH-0.66P26 only needs to pass through one of the L1, L2 two wires of the isolation transformer secondary side output terminal, but can not pass through the two wires simultaneously. The output is connected with the 2×1.5mm² wire to the 15, 16 terminals of AIM-M10, which is not allowed for grounding.

(5) In order to reliably monitor the grounding insulation of the isolation power system, the 11, 12

terminals of AIM-M10 insulation monitor should be reliably connected to IT system (which can be connected in parallel to the output terminal of the isolation transformer) with $2 \times 1.5 \text{mm}^2$ multicore copper wires, and the 1, 2 terminals should be respectively connected to the on-site equipotential terminals (or the grounding terminals in the isolation power cabinet) with two independent 4mm^2 yellow-green grounding wires.

(6) When AID150 centralized alarm and display instrument monitors multiple sets of AIM-M10 at the same time, the communication line should be connected by hand (that is, after the communication line of the previous meter is connected to the communication terminal of this meter, it is led out from the terminal of this meter and connected to the communication terminal of the following table). One matching resistance shall be connected between the two communication terminals at the head and end of RS485 bus, and the resistance recommended and attached with the goods. The resistance is 120Ω . The 5, 6 Terminals of AIM-M10 correspond to + 24 V and G respectively. It is recommended to select 0.5mm^2 wire to supply power to alarm and display instrument.

5.5 Considerations

(1) Medical IT system insulation monitoring and fault locating seven pieces of products should be centrally installed in the isolation power cabinet except for AID series. If the field space is too limited to apply the isolation power cabinet, the isolation transformer can be installed separately, but should not be too far away from the insulation monitor and the field load.

(2) The installation of wiring should strictly follow the wiring diagrams, which should preferably use the pressure connection with the needle-type fittings, and then insert into the corresponding terminal of the instrument and tighten the screws to avoid the abnormal work conditions of instrument caused by loose connection.

(3) The grounding wire of the instrument and the transformer shall be reliably connected with the equipotential terminals in the field. When applying the isolation power cabinet, it should be connected to the grounding terminals in the isolation power supply cabinet, and then to the equipotential terminals in the field.

(4) The current input of AIM-M10 medical insulation monitoring instrument should use a matching AKH-0.66P26 type current transformer. It is recommended to use pressure connection with U-type indenters during wiring operation, and then connect to the CT terminal. Do not directly use the bare head connection, for the considerations of reliable connection and easy disassembly. Before removing the wiring, the CT primary circuits must be cut off or the secondary circuits must be short connection.

(5) Special reminder:

Any isolation transformer will have an impact current when it starts up, and too large impact current may cause the circuit breaker at primary side of the transformer difficult to disconnect or shut down. Therefore, for medical IT systems composed of medical isolation transformers and insulation monitoring products, in the selection of inlet circuit breaker of the isolation

transformer, it is recommended to choose the circuit breakers only with short circuit protection but without overload protection according to GB requirements. If choosing the circuit breaker with overload protection, the circuit breaker should conform to the C and D tripping curves of GB14048.2-2008, and the rated current of the circuit breaker should be determined according to the capacity of the isolation transformer as follows: 10kVA-63A, 8kVA-50A, 6.3kVA-40A, 5kVA-40A, 3.15kVA-20A. If the circuit breaker selection is not in accordance with the above requirements, the company shall not be liable for any medical malpractice caused by the closure difficulty of the circuit breaker or the disconnection of the circuit breaker during operation.

6 Programming and application

6.1 Panel description

(1) AIM-M10 Insulated monitor panel

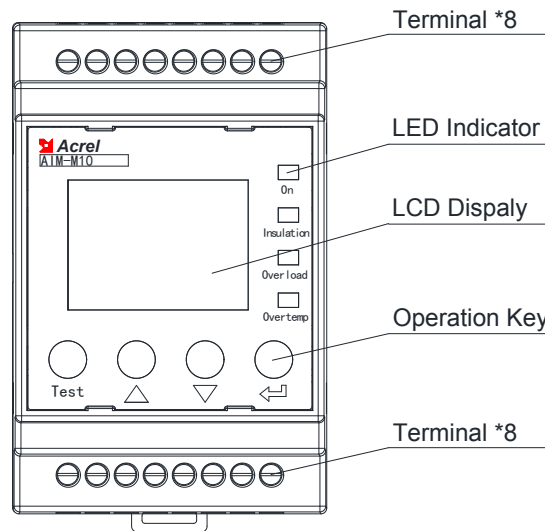

(2) AID10 External alarm and display panel

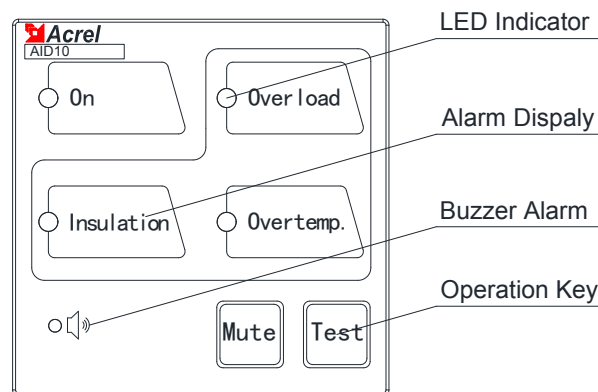

(3) AID150 External alarm and display panel

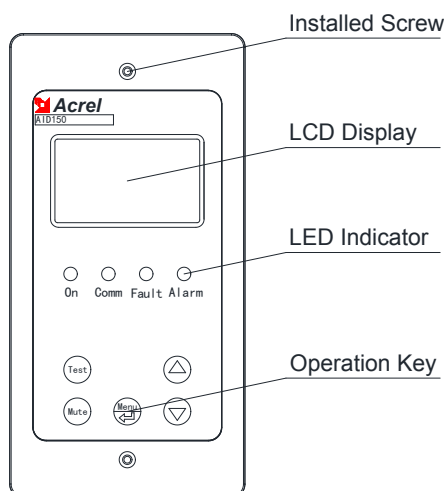

6.2 LED indicator instructions

6.2.1 AIM-M10

Indicator	Instructions
On	When the instrument operation is normal, the indicator light flashes, with the flashing frequency of about one time per second.
Insulation	When the insulation resistance exceeds the alarm value, or when the LL/FK is disconnected, the indicator light flashes to alarm.
Overload	When load current exceeds the total load current of transformer, the indicator light flashes to alarm.
Overtemp.	When testing transformer temperature exceeds the alarm value, or when the temperature sensor wiring is disconnected, the indicator light flashes to alarm.

6.2.2 AID10

Indicator status	Instructions
On	When the device is in normal operation, the indicator flashes, and the flickering frequency is about once a second.
Insulation	When the insulation resistance exceeds the alarm value, the indicator light flashes to alarm.
Overload	When load current exceeds the total load current of transformer, the indicator light flashes to alarm.
Overtemp.	When testing transformer temperature exceeds the alarm value, the indicator light flashes to alarm.

6.2.3 AID150

Indicator status	Instructions
On	When the device is in normal operation, the indicator flashes, and the flickering frequency is about once a second.
Comm	Indicate the status of device communication, when there is data communication, the indicator light flashes.
Fault	When AIM series monitor detect disconnection failure, indicator flashes alarm
Alarm	When AIM-M series monitor exceed threshold alarm, indicator flashing alarm

6.3 Button function descriptions

6.3.1 AIM-M10

AIM-M10 has four buttons in total, namely the " Setting and Enter " shared button, "▲" Up button, "▼" Down button, and "Test" button.

Buttons	Button function
Setting and Enter shared button	In non-programming mode, press this button to enter the programming mode; In programming mode, used as the Enter button.
▲ Up button, ▼ Down button	In non-programming mode, used to view the fault records. In programming mode, used to increase or decrease the values, or to change the protection action status
Test button.	In operation state, used to start the self-test function of instrument.

6.3.2 AID10

AID10 has two buttons in total, namely the "Mute" button and " Test " button.

Key	Functions
Mute button	When there is alarm, press this button to eliminate the alarm sound.
Test button	Used to start the self-test function of instrument.

6.3.3 AID150

The centralized alarm and display instrument has five buttons in total, namely the "Mute" button, " Menu & Enter " shared button, "▲" Up button, "▼" Down button, and "Test" button.

Key	Functions
Mute button	When there is alarm, press this button to eliminate the alarm sound.
▲ Up button, ▼ Down button	In programming mode, used to increase or decrease the value.
Test button	In non-programming mode, used to start the self-test function of instrument.
Menu & Enter shared button	In non-programming mode, press this button to enter the programming mode; In programming mode, used as the Enter button.

6.4 Button operation descriptions

6.4.1 AIM-M10 insulation monitor in non-programming mode

(1) Enter operation mode. The default mode of startup is operation mode. The main interface displays temperature value, insulation resistance value, load rate and current system time.

(2) View the alarm record. In the main interface, press the "▲" or "▼" to enter the "fault record query" interface. Press the "enter" button to confirm, and then you can turn the page through the "▼" or "▲" to query the condition of each fault record in turn. The first record is the latest record and the tenth record is the oldest record.

(3) Instrument self check. Press the "Test" key, the monitor will start the self-test program to simulate overload fault, insulation fault and over temperature fault. In order to detect and judge whether the main fault is normal or not. If the monitor can detect the above three kinds of faults, it indicates that the instrument function is normal.

6.4.2 AIM-M10 insulation monitor in programming mode

(1) Enter programming mode

In normal operation, press Enter to enter the password input page of programming mode. Increase the number by "▲" and decrease it by "▼". After inputting the correct password, press "↵" to enter the programming mode.



(2) In programming mode, the instrument parameters are set

After entering the programming mode, press "▲" or "▼" to view each parameter interface. In the programming mode, press the "↵" key, the parameter will flash, and the parameter can be modified by "▲" and "▼". When there are multiple parameters in the interface, such as alarm value setting interface and time setting interface, when the parameter flashes, "▲" is used to select the parameter and "▼" is used to modify the parameter value. Press "↵" again to exit the parameter modification mode and browse the menu.

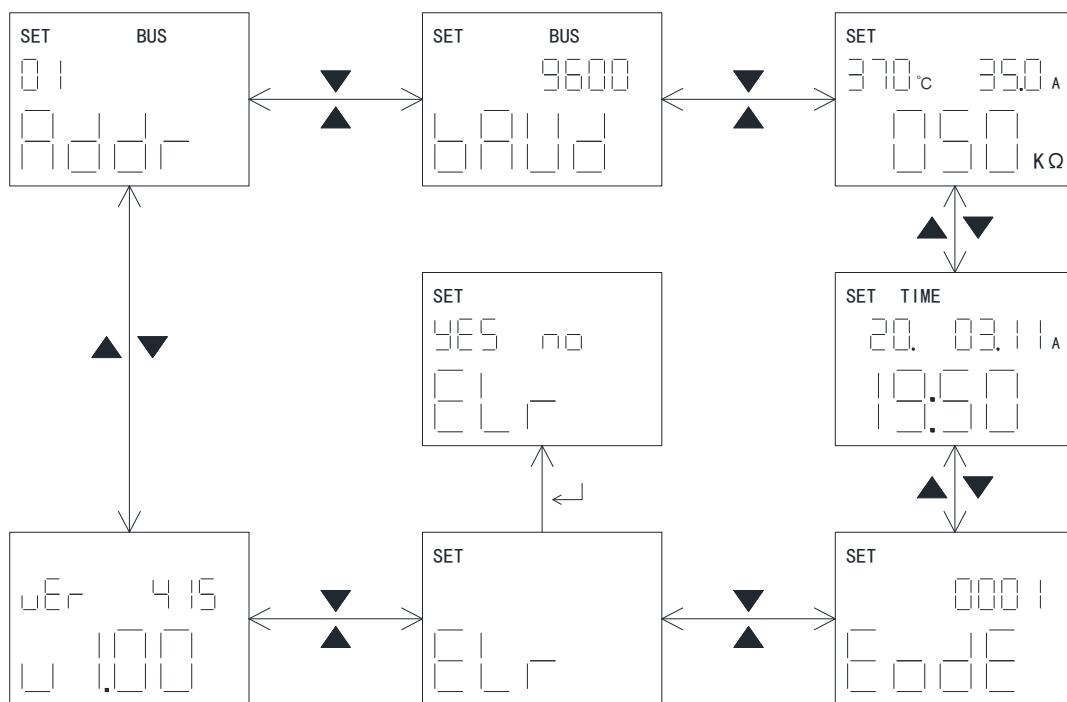

(3) Exit programming mode

In the programming mode, enter the "save parameter" page through the Test key, select "yes" and "no" by Up and Down keys, and the flashing indicates the selection. Press the "↵" key to save the parameters or not, exit the programming mode and enter the operation mode.



6.4.3 AID10 alarm and display key operation

(1) After AID10 and AIM-M10 are connected through RS485 communication, the On light flashes, indicating that the communication is normal. If the operation lamp is normally on, it means the communication is abnormal.

(2) When AID10 detects the fault mark issued by AIM-M10, the corresponding indicator light flashes, and the buzzer rings. Press the Mute key to turn off the buzzer.

(3) When the system is running normally, press the Test key to start the AIM-M10 insulation monitor self-test.

6.4.4 AID150 alarm and display key operation

(1) Description of the Operating Interface

After the system is powered on, if there is no fault alarm, AID150 shows the normal operation interface as shown in the following figure. The black boxes in the figure indicate that the corresponding address serial number is connected to the instrument communication, and the black boxes indicate that there is no instrument connection, or that the communication is not connected. When the insulation monitor or residual current monitor detects the fault, AID150 displays the corresponding alarm interface and sends out the corresponding sound and light alarm.

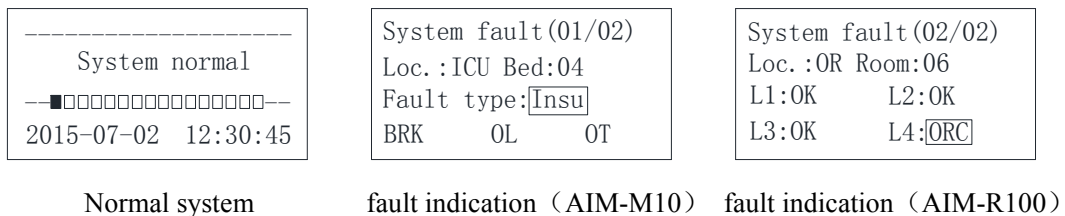

(2) Fault record viewing interface operations and descriptions

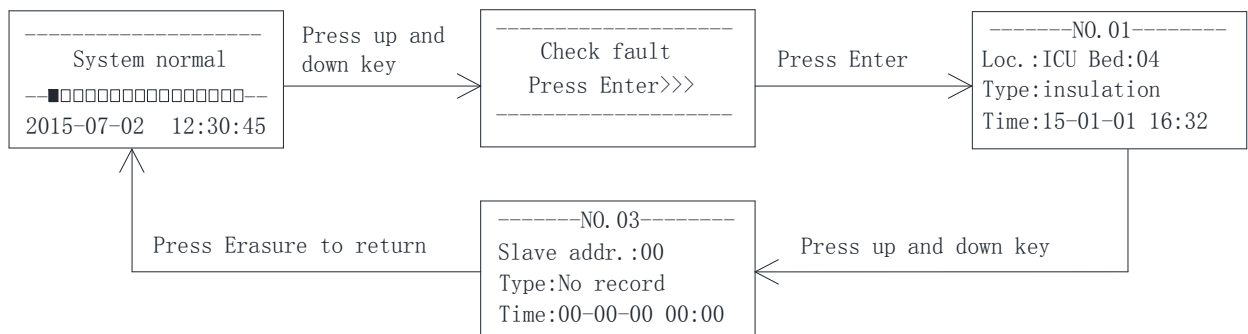

(3) Programming Interface Operation and Explanation

The operation method and process are shown in the following flow chart.

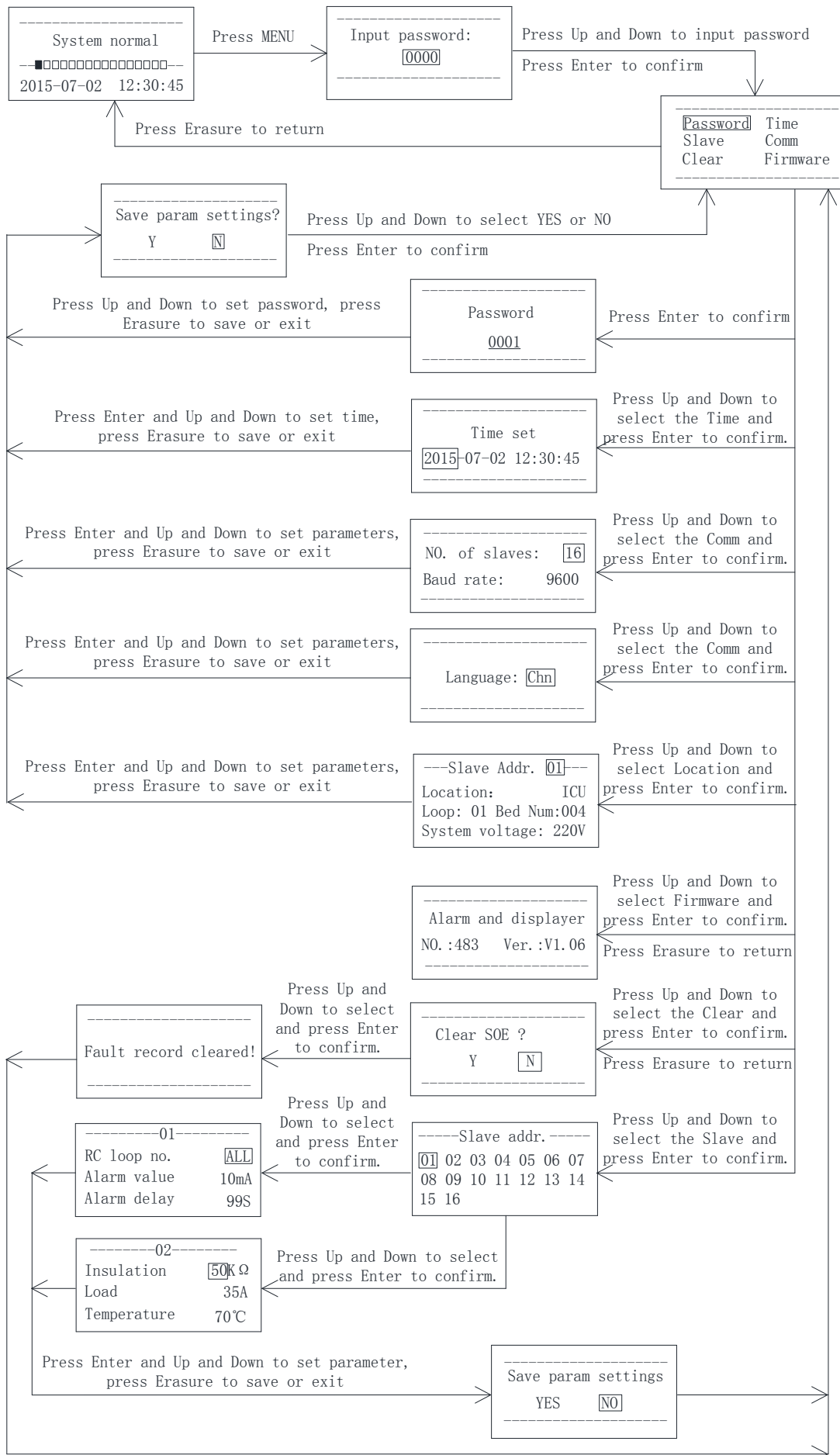

Note:

When AID150 is in use, the total number of Insulation Monitors and residual current monitors connected to RS485 bus should be set first, and the total number should not exceed 16 sets. This parameter is in [communication settings] in the menu. The slave address of each insulation monitor and residual current monitor shall be numbered from 1 to 16 as far as possible. When the total number of Insulation Monitors and residual current monitors exceeds 16 sets, the number of AID150 shall be increased and networking shall be conducted separately.

7 Communication protocol

7.1 Modbus-RTU communication protocol

Meter RS485 interface adopts Modbus-RTU communication protocol, which defines the address, function code, data, check code in detail. It is the necessary content to complete the data exchange between the host and slave machine.

7.2 Introduction to the function code

7.2.1 Function code 03H or 04H: Read the registers

This function allows the user to acquire the data collected and recorded by equipment and the system parameters. The number of data requested by hosts has no limit, but cannot exceed the defined address range.

The following example shows how to read a measured insulation resistance value from No.01 slave computer, with the address of the value of 0008H.

The host computer sends		Send message	The slave computer returns		Return message
Address code		01H	Address code		01H
Function code		03H	Function code		03H
Start address	High byte	00H	Bytes		02H
	Low byte	08H	Register data	High byte	00H
Number of registers	High byte	00H		Low byte	50H
	Low byte	01H	CRC check code	Low byte	B8H
CRC check code	Low byte	05H		High byte	78H
	High byte	C8H			

7.2.2 Function code 10H: Write the registers

The function code 10H allows the user to change the contents of multiple registers, which can write the time and date in this meter. The host can write up to 16 (32 bytes) data at a time.

The following example shows a preset address of 01 with an installation date and time of 12:00, Friday, December 1, 2009.

The host computer sends		Send message	The slave computer returns		Return message
Address code		01H	Address code		01H

Function code		10H
Start address	High byte	00H
	Low byte	04H
Number of registers	High byte	00H
	Low byte	03H
Number of registers		06H
0004H data	High byte	09H
	Low byte	0CH
0005H data	High byte	01H
	Low byte	05H
0006H data	High byte	0CH
	Low byte	00H
CRC check code	Low byte	A3H
	High byte	30H

Function code		10H
Start address	High byte	00H
	Low byte	04H
Number of registers	High byte	00H
	Low byte	03H
CRC check code	Low byte	C1H
	High byte	C9H

7.3 AIM-M10 parameter address table

No.	Address	Parameter	Read-Write	Value Range	Data Type
1	0000H	Protecting password	R/W	0001~9999 (Default 0001)	word
2	0001H high	RS485 address1	R/W	1~247 (Default 1)	word
	0001H low	RS485 Baud1	R/W	1~3: 4800, 9600, 19200 (unit bps) (Default 2)	
3	0002H high	Reserve			word
	0002H low	Reserve			
4	0003H high	Reserve			word
	0003H low	Reserve			
5	0004H high	Year	R/W	1~99	word
	0004H low	Month	R/W	1~12	
6	0005H high	Day	R/W	1~31	word
	0005H low	Week	R/W	1~7	
7	0006H high	Hour	R/W	0~23	word
	0006H low	Minute	R/W	0~59	
8	0007H high	Second	R/W	0~59	word
	0007H low	Reserve			
9	0008H	Insulation resistance	R/W	10~999 (Unit is kΩ)	word

10	0009H	Load current	R/W	0~500 (Unit is 0.1A)	word	
11	000AH	Transformer temperature	R/W	-50~200 (Unit is °C)	word	
12	000BH high	Reserve			word	
	000BH low	Fault type	R	Bit0: 0 normal; 1 Insulation resistance fault Bit1: 0 normal; 1 Overload fault Bit2: 0 normal; 1 Transformer overheat fault Bit3: Reserve Bit4: 0 normal; 1 PE or KE disconnection fault Bit5: 0 normal; 1 Temperature sensor disconnection Bit6: Reserve Bit7: Reserve		
13~16	000CH~000FH	Reserve				
17	0010H	Insulation resistance set value	R/W	10~999 (Unit kΩ) (default 50)	word	
18	0011H	Load current set value	R/W	14, 18, 22, 28, 35, 45 (Unit A) (default 35)	word	
19	0012H	Transformer temperature set value	R/W	0~200 (Unit °C) (default 70)	word	
20~24	0013H~0017H	Reserve				
25	0018H high	Event	Reserve		word	
	0018H low		STA1	SOE1 type: 0~6 0: No fault record 1: Insulation fault 2: Overload fault 3: Over temperature fault 4: LI disconnection 5: PK disconnection 6: TC disconnection		
26	0019H high	record 1	Year1	R	SOE1 time - year	word
	0019H low		MoTh1	R	SOE1 time - month	
27	001AH high		Day1	R	SOE1 time - day	word
	001AH low		Hour1	R	SOE1 time - hour	
28	001BH high		Minute1	R	SOE1 time - minute	word
	001BH low		Second1	R	SOE1 time - second	
29~64	001CH~003FH	Store the other 9 event records in the same format as the first one				

8 Typical applications

Application of four-piece set of medical IT system insulation monitoring products in operating room.

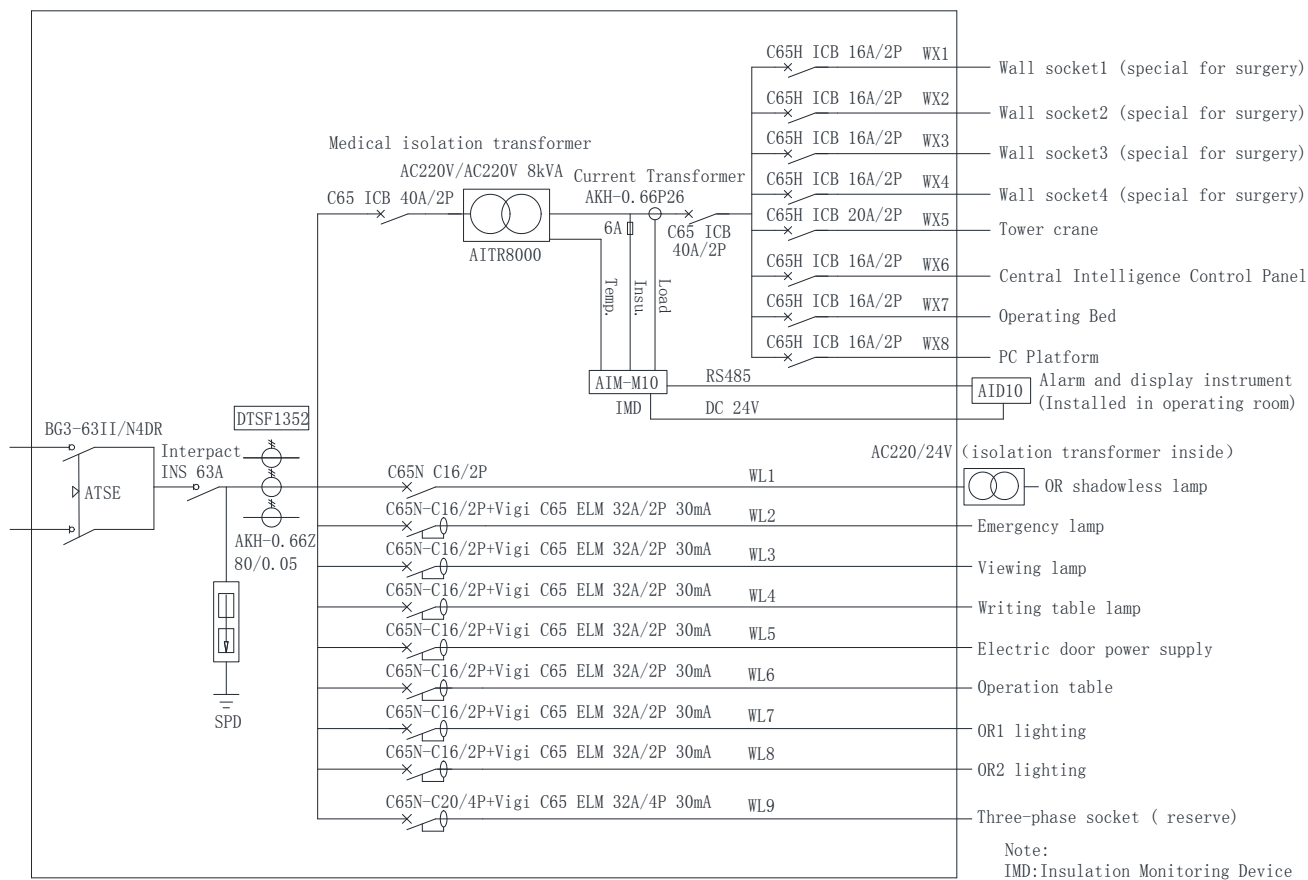

Note: The grounding bat in the isolated power supply cabinet should be connected reliably with the equipotential terminals in the field.

9 Power on and debugging instructions

9.1 Wiring check

For each set of IT system, the wiring check should be conducted before power on, mainly checking whether there is wrong, missed or short connection. The examination can be conducted sequentially in the following order according to the wiring diagrams shown in section 5.4 of this manual:

(1) Check whether each four-piece set constitutes an independent IT distribution system, and ensure that the current, resistance and temperature signals monitored by each insulation monitor are connected to the same isolation transformer and its IT system.

(2) Check the AIM-M10 DC power output. Whether the 5 and 6 (+ 24 V, G) of the 24V output end are respectively reliably connected with the 24 V and G terminals of the AID series external display device, and the positive and negative poles are correct.

(3) Check whether the 15 (I0) and 16(I1) terminals of AIM-M10 in each system are reliably connected to the terminals of the transformer AKH-0.66P26 socketed to the secondary side of the corresponding isolation transformer, and are not grounded. The transformer only passes one of the two lines of the output terminals of the isolation transformer.

(4) Check whether 17 (T0) and 18 (T1) terminals of AIM-M10 in each system are connected with

the two ST terminals of isolation transformer and connected reliably.

(5) Check whether the terminals 11 (L1) and 12 (L2) of AIM-M10 in each set of systems are reliably connected with the two wires of IT system (i.e. output end of secondary side of isolation transformer).

(6) Check whether the 1 (FE) and 2 (KE) terminals of AIM-M10 in each system are connected to the field equipotential terminal block with wires, and whether the S terminal of the isolation transformer is also reliably connected with the equipotential terminal block.

(7) Check whether terminals 3 (A) and 4 (B) of RS485 communication of AIM-M10 instrument in each system are connected with terminals a and B of AID series external alarm display instrument in a hand-in-hand manner, and the positive and negative are correct.

(8) If each isolation transformer has a cooling fan, check whether the power control of the cooling fan is connected to the 7 and 8 terminals of AIM-M10 in the system.

9.2 Common faults and eliminations

Make sure the wirings are correct and power on the system. Then check whether each meter is abnormal, and whether there is a fault alarm in AIM-M10. For common problems, the causes can be determined and the faults can be eliminated according to the phenomenon of each instrument and the fault types:

Equipment name	Fault phenomenon	Possible causes and troubleshooting
AIM-M10 insulation monitor	LCD display: FK disconnection, and the insulation indicator.	1 and 2 terminals of AIM-M10 are not reliably connected to the equipotential terminals. Check the wirings and make sure they are reliably connected.
	LCD display: TC disconnection fault, and the overheat indicator.	17 and 18 terminals of AIM-M10 are not reliably connected to the two ST terminals of the isolation transformer. Check the wirings and make sure they are reliably connected.
	LCD display: insulation fault, and the insulation indicator.	At least one of the two lines in the IT system at the secondary side of the isolation transformer has a grounding fault, after elimination it can be restored to normal.
	The instrument is not lit.	The 220V power supply of AIM-M10 is not connected well. Check the wirings of 11 and 12 terminals and make sure they are reliably connected.
AID series centralized alarm and display instrument	The instrument is not lit.	The 24V power supply is not connected well. Check the wirings of 24V and G terminals and rewire.
	Communication indicator does not flash	①If the slave address of AIM-M10 is not set to the default 1, or the slave Baud is not set to the default 9600, it needs to be set as the default value. ②If the communication line with AIM-M10 in the system is not well connected, check the communication line and confirm whether the matching resistance is connected properly.

Note: If the above faults occur, interrupt the power to troubleshoot, and adjust the wirings until everything is normal.

9.3 Settings and debugging

(1) When entering the menu settings, ACREL medical IT products need to enter the password. The initial password of all medical IT products is 0001.

(2) After the system is powered on, set the AIM-M10 load current alarm value according to the capacity of the isolation transformer. The corresponding relations between alarm current and isolation transformer capacity are: 45A---10kVA, 35A---8kVA, 28A---6.3kVA, 14A---3.15kVA. After you set up, follow the process step by step to exit and save the setting parameters. The default alarm current value of the instrument is 35A, if the matching transformer is 8kVA, then this parameter does not need to be set 1.

(3) Communication parameter setting. In order to realize the centralized monitoring function of multiple sets of insulation monitors through the centralized alarm and display AID150, it is necessary to set the slave addresses of each AIM-M10 in turn (the master address is used to communicate with the upper computer, if there is no upper computer, it is not necessary to set it), and then the communication between the instruments should be connected hand in hand. After setting, the head and end of the communication bus are connected with a matching resistor of 120Ω (the resistance must be added, otherwise communication may not be possible). AID150 does not need to set RS485 communication address. When using AID10 type external alarm and display instrument to monitor a set of AIM-M10 insulation monitor, the slave address of the insulation monitor should be 1, and the slave baud rate should be 9600, otherwise it can not communicate.

(4) When AID150 is used, the total number of insulation monitors or residual current monitors connected to RS485 bus should be set first, and the total number should not exceed 16 sets. In AID150, the setting of this parameter is in the [Comm set] submenu of the menu. The slave address of each insulation monitor or residual current monitor shall be numbered from 1 to 16 as far as possible. When the total number exceeds 16 sets, the number of AID150 shall be increased and networking shall be conducted separately.

Jiangsu Acrel Electrical MFG Co.,Ltd.(Production Base)

Address : No31HongtuRd,NanzhaJiangyinJiangsu

Website: www.acrel.gr

Sales manager : Tim Ma

Tel/whatsapp/wechat : 8618761599716

E-mail : tim.ma@email.acrel.cn